



EMERSON[™]
Industrial Automation

Unimotor

Product Data
055 to 250 Frames
0.72 Nm to 136 Nm
(408 Nm Peak)





055-250 Unimotor Product Data

Unimotor  is a high performance brushless AC servo motor range matched for use with Control Techniques drives. 'Unimotor' stands for flexible motor, designed to accommodate a wide range of applications. The motors are available in seven frame sizes with various mounting arrangements and motor lengths.

Reliability and innovation

Unimotor  is designed using a proven development process that prioritises innovation and reliability. This process has resulted in Control Techniques' market leading reputation for both performance and quality.

Matched motor and drive combinations

Control Techniques motors and drives are designed to function as an optimised system. Unimotor  is the perfect partner for Unidrive , Digitax ST and Epsilon EP drives.

Features

Unimotor  is suitable for a wide range of industrial applications, due to its extensive range of features

- Torque range: from 0.72 Nm to 136 Nm
- Standard and high energy parking brakes
- Numerous connector variants, e.g. vertical, 90° low profile, 90° rotatable and hybrid box on frame size 250
- Variety of flange possibilities (IEC/NEMA)
- Various shaft diameters; keyed or plain
- IP65 conformance; sealed against water spray and dust when mounted and connected
- Low inertia for high dynamic performance; high inertia option available
- World class performance
- Supported by rigorous testing for performance and reliability
- Optional high peak torque motors; up to 5 times stall torque
- Winding voltages of 400V and 220V
- Rated speeds include 1500 rpm, 2000 rpm, 3000 rpm, 4000 rpm, 6000 rpm and others available

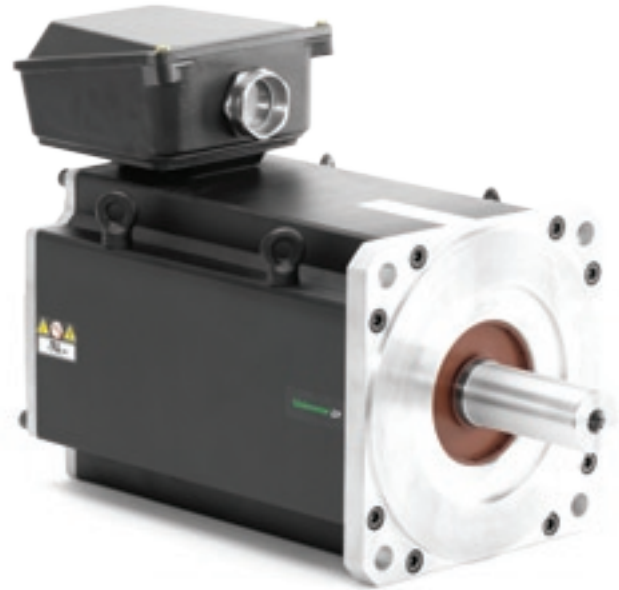

Faster set-up, optimised performance

When a Control Techniques servo drive is connected to a Unimotor  fitted with a SinCos or Absolute encoder, it can recognise and communicate with the motor to obtain the “electronic nameplate” data. This motor data can then be used to automatically optimise the drive settings. This feature simplifies commissioning and maintenance, ensures consistent performance and saves time.

Accuracy and resolution to suit your application requirements

Choosing the right feedback device for your application is critical in getting optimum performance. Unimotor  has a range of feedback options that offer different levels of accuracy and resolution to suit most applications:

- Resolver: robust for extreme applications and conditions - low accuracy, medium resolution
- Inductive absolute: medium accuracy, medium resolution
- Incremental encoder: high accuracy, medium resolution
- Optical SinCos: high accuracy, high resolution
- Single turn and multi-turn: Hiperface and EnDAT protocols supported

Conformance and standards



FM 30610





RoHS
Compliant





Ideal for retrofit

Unimotor  is an ideal retrofit choice with features to ensure it can integrate easily with your existing servo motor applications. Unimotor  has been designed so that existing Unimotor customers can easily migrate to the new platform. All connector interface types and mounting dimensions remain the same. If you are planning to retrofit your system, Unimotor  is the obvious choice.

Custom built motors

As part of our commitment to you, we can design special products to meet your application specific requirements.

Wide range of complementary accessories

Unimotor  has a wide range of complementary accessories to meet all your system requirements:

- Feedback and power cables for static and dynamic applications
- Fan boxes
- Gearboxes
- Connectors

All around the world, just around the corner

Backed by Control Techniques' world wide support network in 65 countries through 89 subsidiary Drive Centres and resellers.

Torque performance

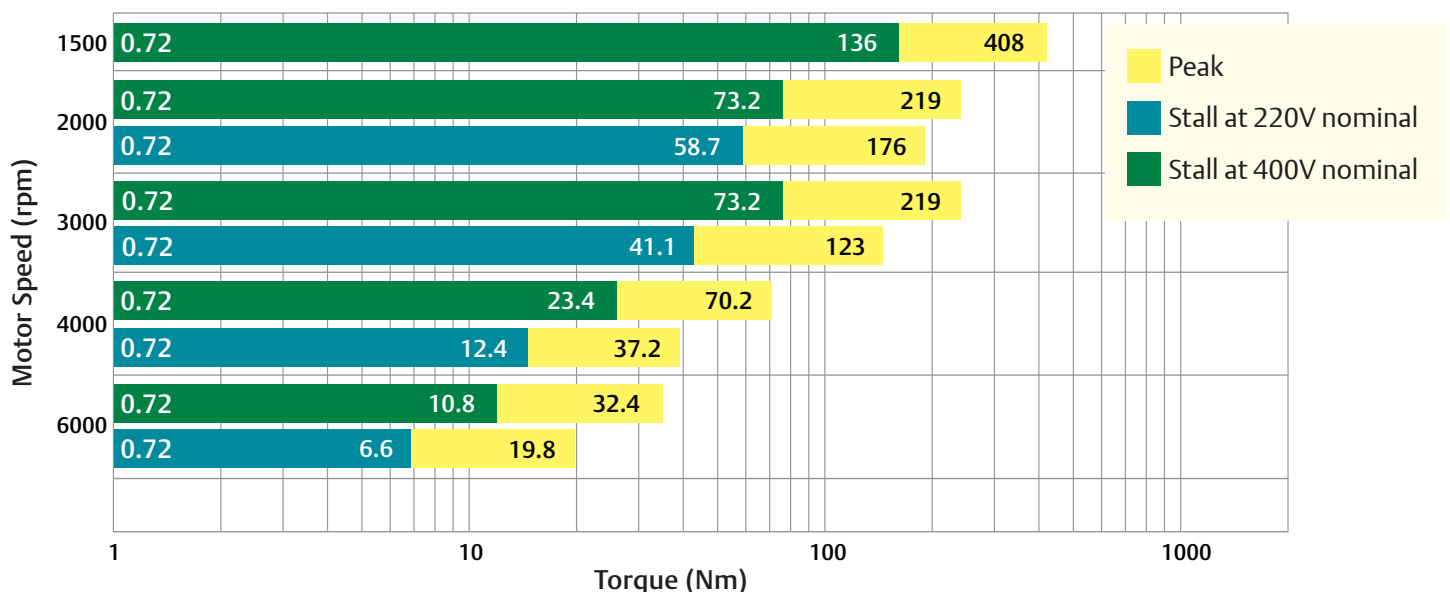

NB: The selection of drive-motor combinations should be based on duty/load profiles of the application

Ordering information

Use the information below in the illustration to create an order code for a **Unimotor** 

The details in the band are an example of an order reference (Std = Standard selection, Opt = Optional selection)

095	U	2	B	30	1	V
Frame size	Motor voltage	Peak torque selection	Stator length	Winding speed	Brake	Connection type
055	E = 220V	055 frame only	A	055 frame only	055 frame only	055 frame only
075	U = 400V	2 = Standard peak torque	B	30 = 3000 rpm (Std)	0 = Not fitted (Std)	A = Power and Signal 90° fixed
095	250 frame only	075-142 frame only	C	60 = 6000 rpm	1 = Parking brake fitted 24Vdc	B = Power and Signal 90° rotatable (Std)
115	U = 400V	2 = Standard peak torque	D	075-190 frame only	X = Special	C = Power 90° rotatable and Signal vertical
142		P = High peak torque	E	10 = 1000 rpm	075-190 frame only	
190		190-250 frame only	F	20 = 2000 rpm	0 = Not fitted (Std)	V = Power and Signal vertical
250		2 = Standard peak torque	G	25 = 2500 rpm	1 = Parking brake fitted 24Vdc	X = Special
			H	30 = 3000 rpm		075-190 frame only
				40 = 4000 rpm	5 = High energy dissipation	A = Power and Signal 90° fixed
				45 = 4500 rpm	X = Special	B = Power and Signal 90° rotatable
				50 = 5000 rpm		
				60 = 6000 rpm		
				250 frame only	250 frame only	C = Power 90° rotatable and Signal vertical
				10 = 1000 rpm	0 = Not fitted (Std)	
				15 = 1500 rpm	5 = High energy dissipation	V = Power and Signal vertical (Std)
				20* = 2000 rpm		
				25* = 2500 rpm		X = Special
						250 frame only
						C = Power and Signal 90° fixed
						*H = Power hybrid box and Signal 90° (Std)
						V = Power and Signal vertical

* D and E lengths, winding speed equal and above 2500rpm must use the Hybrid box. F lengths, winding speed equal and above 2000rpm must use the Hybrid box.

** Optional PCD's will have a different register diameter from the standard motors. Please consult Drive Centre or Distributors for details.

*** Available on 190 frame only

	A	CA	A	100	190
	Output shaft	Feedback device	Inertia	PCD**	Shaft diameter**
	A = Key (Std)	055 frame only	055 frame only	055 frame only	
	B = Plain shaft	AR = Resolver	A = Standard	063 Std	09.0 A Std
	X = Special	CP = Incremental Encoder 4096 ppr	075-190 frame only	070 Opt	11.0 B-C Std
		MP = Incremental Encoder 2048 ppr	A = Standard		14.0 Max
		KP = Incremental Encoder 1024 ppr	B = High Inertia	075 frame only	
		EM = Inductive Sincos Multi-turn EQI 1130	250 frame only	075 Std	11.0 A Std
		FM = Inductive Sincos Single turn ECI 1118	A = Standard	080 Opt	14.0 B-D Std
		TL = Optical Sincos Multi-turn SKM 36		085 Opt	19.0 Max
		UL = Optical Sincos Single turn SKS 36		095 frame only	
		XX = Special		100 Std	14.0 A Std
		075-142 frame only		098 Opt	19.0 B-E Std
		EC = Inductive Sincos Multi-turn EQI 1331		115 Opt	22.0 Max
		FC = Inductive Sincos Single turn ECI 1319		115 frame only	
		EB = Optical Sincos Multi-turn EQN 1325		115 Std	19.0 A-C Std
		FB = Optical Sincos Single turn ECN 1313		130 Opt	24.0 D-E Std
		AE = Resolver		145 Opt	32.0 Max
		CA = Incremental Encoder 4096 ppr		142 frame only	
		MA = Incremental Encoder 2048 ppr		165 Std	24.0 A-E Std
		KA = Incremental Encoder 1024 ppr		149 Opt	32.0 Max
		RA = Optical Sincos Multi-turn SRM 50		190 frame only	
		SA = Optical Sincos Single turn SRS 50		215 Std	32.0 A-H Std
		XX = Special			42.0 Max
		190-250 frame only		250 frame only	
		EB = Optical Sincos Multi-turn EQN 1325		300 Std	48.0 D-F Std
		FB = Optical Sincos Single turn ECN 1313			
		AE = Resolver			
		CA = Incremental Encoder 4096 ppr			
		MA = Incremental Encoder*** 2048 ppr			
		RA = Optical Sincos Multi-turn SRM 50			
		SA = Optical Sincos Single turn SRS 50			
		XX = Special			

055-250 Unimotor Product Data

For 3 Phase VPWM drives 200-240Vrms

$\Delta t = 100^\circ\text{C}$ winding 40°C maximum ambient

All data subject to +/-10% tolerance

Motor frame size (mm)		055E2			075E2				095E2				
Frame length		A	B	C	A	B	C	D	A	B	C	D	E
Continuous stall torque (Nm)		0.72	1.40	2.11	1.2	2.2	3.1	3.9	2.3	4.3	5.9	7.5	9.0
Standard (2) peak torque selection max (Nm)		2.75	5.50	8.25	3.6	6.6	9.3	11.7	6.9	12.9	17.7	22.5	27.0
High (P) peak torque selection max (Nm)		N/A	N/A	N/A	6	11	15.5	19.5	10.4	19.4	26.6	33.8	40.5
Standard inertia (kgcm ²)		0.12	0.23	0.34	0.7	1.2	1.6	2.0	1.8	2.9	4.0	5.1	6.2
High inertia (kgcm ²)					1.1	1.5	2.0	2.4	3.7	4.8	5.9	7.0	8.1
Winding thermal time const. (s)					81	74	94	100	172	168	183	221	228
Standard motor weight unbraked (kg)		1.20	1.50	1.80	3.60	4.40	5.20	6.00	5.10	6.30	7.50	8.70	9.90
Standard motor weight braked (kg)		1.60	1.90	2.20	4.10	4.90	5.70	6.50	5.70	6.90	8.70	9.30	10.50
Rated speed 2000 (rpm)		$K_t \text{ (Nm/A)} =$ $K_e \text{ (V/krpm)} =$			$K_t \text{ (Nm/A)} = 1.40$ $K_e \text{ (V/krpm)} = 85.50$								
Rated torque (Nm)		C/D	C/D	C/D	1.1	2.1	3.0	3.8	2.2	4.0	5.5	6.9	8.2
Stall current (A)					0.9	1.6	2.3	2.8	1.7	3.1	4.3	5.4	6.5
Rated power (kW)					0.23	0.44	0.63	0.80	0.46	0.84	1.15	1.45	1.72
R (ph-ph) (Ω)					45.8	15.3	8.5	5.72	19.4	6.2	3.16	2.31	1.71
L (ph-ph) (mH)					98.8	43.4	27.9	20.2	59.2	25.8	16.0	12.6	10.1
Rated speed 3000 (rpm)		$K_t \text{ (Nm/A)} =$ $K_e \text{ (V/krpm)} =$			$K_t \text{ (Nm/A)} = 0.93$ $K_e \text{ (V/krpm)} = 57.00$								
Rated torque (Nm)		0.60	1.20	1.80	1.1	2.0	2.8	3.5	2.0	3.9	5.4	6.8	8.1
Stall current (A)		0.98	1.68	2.46	1.3	2.4	3.4	4.2	2.5	4.7	6.4	8.1	9.7
Rated power (kW)		0.21	0.43	0.64	0.35	0.63	0.88	1.10	0.63	1.23	1.70	2.14	2.54
R (ph-ph) (Ω)		30.0	14.7	9.6	18.9	6.26	3.50	2.38	8.03	2.68	1.57	1.03	0.77
L (ph-ph) (mH)		67.3	43.0	30.9	42.5	18.4	11.9	8.82	25.6	12.0	7.91	5.60	4.65
Rated speed 4000 (rpm)		$K_t \text{ (Nm/A)} =$ $K_e \text{ (V/krpm)} =$			$K_t \text{ (Nm/A)} = 0.72$ $K_e \text{ (V/krpm)} = 44.00$								
Rated torque (Nm)		C/D	C/D	C/D	1.0	1.7	2.3	2.9	1.8	3.0	4.0	4.9	5.7
Stall current (A)					1.7	3.1	4.4	5.5	3.2	6.0	8.2	10.5	12.5
Rated power (kW)					0.42	0.71	0.96	1.21	0.75	1.26	1.68	2.05	2.39
R (ph-ph) (Ω)					10.2	3.39	1.92	1.48	5.15	1.64	0.92	0.62	0.43
L (ph-ph) (mH)					24.6	10.8	7.14	5.42	15.5	6.77	4.61	3.46	2.54
Rated speed 6000 (rpm)		$K_t \text{ (Nm/A)} =$ $K_e \text{ (V/krpm)} =$			$K_t \text{ (Nm/A)} = 0.47$ $K_e \text{ (V/krpm)} = 28.50$								
Rated torque (Nm)		0.48	0.91	1.35	0.9	1.6	2.1	2.6	1.3	2.1	2.8	C/D	C/D
Stall current (A)		1.66	3.33	4.80	2.6	4.7	6.6	8.3	4.9	9.2	12.6		
Rated power (kW)		0.33	0.63	0.99	0.57	1.01	1.32	1.63	0.82	1.32	1.76		
R (ph-ph) (Ω)		9.6	3.8	2.5	4.5	1.49	0.95	0.65	2.01	0.67	0.35		
L (ph-ph) (mH)		21.5	11.1	8.1	10.7	4.73	3.10	2.33	6.41	3.01	1.77		

C/D Consult Drive Centre/Distributor

N/A Not available

The information contained in this specification is for guidance only and does not form part of any contract

	115E2					142E2					190E2							
	A	B	C	D	E	A	B	C	D	E	A	B	C	D	E	F	G	H
	3.5	6.6	9.4	12.4	15.3	5.7	10.8	15.3	19.8	23.4	C/D	21.8	C/D	41.1	C/D	58.7	C/D	73.2
	10.5	19.8	28.2	37.2	45.9	17.1	32.4	45.9	59.4	70.2		65.4		123.0		176.0		219.0
	14	26.4	37.6	49.6	61.2	22.8	43.2	61.2	79.2	93.6	N/A	N/A	N/A	N/A	N/A	N/A	N/A	N/A
	4.4	6.7	9.0	11.4	13.8	9.0	15.6	22.2	28.8	35.4		48.7		86.4		123.1		161.8
	9.5	11.8	14.1	16.6	18.9	23.3	29.9	36.5	43.1	49.7		93.9		131.6		168.3		207.0
	175	185	198	217	241	213	217	275	301	365		240		242		319		632
	7.80	9.70	11.60	13.50	15.40	10.00	13.30	16.10	18.90	21.70		25.30		33.90		42.50		51.30
	9.00	10.90	12.80	14.70	17.20	12.20	15.00	17.80	19.60	23.40		27.30		35.90		44.50		53.10
	3.2	6.1	8.7	10.8	14.0	5.3	10.3	14.6	18.4	21.3	C/D	20.0	C/D	36.9	C/D	50.4	C/D	C/D
	2.5	4.8	6.8	8.9	11.0	4.1	7.8	11.0	14.2	16.8		15.6		29.4		42.0		
	0.67	1.28	1.82	2.26	2.93	1.11	2.16	3.06	3.85	4.46		4.19		7.73		10.6		
	9.09	2.82	1.51	0.99	0.82	4.28	1.33	0.75	0.45	0.32		0.50		0.15		0.10		
	47.3	20.6	13.1	9.54	7.86	33.7	15.1	10.3	6.96	5.58		7.98		3.32		2.73		
	3.0	5.5	8.1	10.4	12.6	4.9	9.0	12.2	15.8	N/A	C/D	19.2	C/D	33.0	C/D	C/D	C/D	N/A
	3.8	7.1	10.2	13.4	16.5	6.2	11.7	16.5	21.3			23.5		44.2				
	0.94	1.73	2.54	3.27	3.96	1.54	2.83	3.83	4.96			6.03		10.4				
	4.01	1.30	0.73	0.47	0.37	1.90	0.59	0.31	0.20			0.25		0.08				
	20.1	9.16	6.07	4.26	3.49	15.0	6.85	4.20	1.94			3.98		1.87				
	2.5	4.7	6.3	7.5	C/D	3.6	7.0	C/D	N/A	N/A	N/A	N/A	N/A	N/A	N/A	N/A	N/A	N/A
	4.9	9.2	13.1	17.3		8.0	15.0											
	1.05	1.97	2.64	3.14		1.51	2.93											
	2.62	0.82	0.44	0.29		1.20	0.36											
	12.6	5.48	3.57	2.53		9.45	4.08											
	2.2	4.0	C/D	N/A	N/A	2.9	C/D	N/A	N/A	N/A	N/A	N/A	N/A	N/A	N/A	N/A	N/A	N/A
	7.5	14.1				12.2												
	1.38	2.51				1.82												
	0.96	0.30				0.49												
	4.80	2.09				3.96												

Stall torque, rated torque and power relate to maximum continuous operation tested in a 20°C ambient at 12kHz drive switching frequency

All other figures relate to a 20°C motor temperature. Maximum intermittent winding temperature is 140°C

Control Techniques have an ongoing process of development and reserve the right to change the specification without notice

055-250 Unimotor Product Data

Servo motor for 3 Phase VPWM drives 380-480Vrms

$\Delta t = 100^\circ\text{C}$ winding 40°C maximum ambient

All data subject to +/-10% tolerance

Motor frame size (mm)		055U2			075U2				095U2				
Frame length		A	B	C	A	B	C	D	A	B	C	D	E
Continuous stall torque (Nm)		0.72	1.40	2.11	1.2	2.2	3.1	3.9	2.3	4.3	5.9	7.5	9.0
Standard (2) peak torque selection max (Nm)		2.75	5.50	8.25	3.6	6.6	9.3	11.7	6.9	12.9	17.7	22.5	27.0
High (P) peak torque selection max (Nm)		N/A	N/A	N/A	6	11	15.5	19.5	10.4	19.4	26.6	33.8	40.5
Standard inertia (kgcm ²)		0.12	0.23	0.34	0.7	1.2	1.6	2.0	1.8	2.9	4.0	5.1	6.2
High inertia (kgcm ²)					1.1	1.5	2.0	2.4	3.7	4.8	5.9	7.0	8.1
Winding thermal time const. (s)					81	74	94	100	172	168	183	221	228
Standard motor weight unbraked (kg)		1.20	1.50	1.80	3.60	4.40	5.20	6.00	5.10	6.30	7.50	8.70	9.90
Standard motor weight braked (kg)		1.60	1.90	2.20	4.10	4.90	5.70	6.50	5.70	6.90	8.70	9.30	10.50
Rated speed 2000 (rpm)	K_t (Nm/A) = K_e (V/krpm) =				K_t (Nm/A) = 2.40 K_e (V/krpm) = 147.00								
Rated torque (Nm)		C/D	C/D	C/D	1.1	2.1	3.0	3.8	2.2	4.0	5.5	6.9	8.2
Stall current (A)					0.5	1.0	1.3	1.7	1.0	1.8	2.5	3.2	3.8
Rated power (kW)					0.23	0.44	0.63	0.80	0.46	0.84	1.15	1.45	1.72
R (ph-ph) (Ω)					144	48.2	25.0	15.7	59.0	17.0	9.90	6.00	4.30
L (ph-ph) (mH)					214	99.2	59.2	44.7	131	54.5	36.5	25.6	18.9
Rated speed 3000 (rpm)	K_t (Nm/A) = K_e (V/krpm) =	0.74 45.00	1.48 89.50	1.58 95.70	K_t (Nm/A) = 1.60 K_e (V/krpm) = 98.00								
Rated torque (Nm)		0.60	1.20	1.80	1.1	2.0	2.8	3.5	2.0	3.9	5.4	6.8	8.1
Stall current (A)		0.98	0.95	1.34	0.8	1.4	2.0	2.5	1.5	2.7	3.7	4.7	5.7
Rated power (kW)		0.21	0.43	0.64	0.35	0.63	0.88	1.10	0.63	1.23	1.70	2.14	2.54
R (ph-ph) (Ω)		30.0	46.0	32.0	60.8	20.1	10.5	7.5	24.5	6.80	4.00	2.50	2.00
L (ph-ph) (mH)		67.3	132.3	103.0	98.4	41.8	27.6	19.7	57.9	24.3	15.5	10.9	8.50
Rated speed 4000 (rpm)	K_t (Nm/A) = K_e (V/krpm) =				K_t (Nm/A) = 1.20 K_e (V/krpm) = 73.50								
Rated torque (Nm)		C/D	C/D	C/D	1.0	1.7	2.3	2.9	1.8	3.0	4.0	4.9	5.7
Stall current (A)					1.0	1.9	2.6	3.3	2.0	3.6	5.0	6.3	7.5
Rated power (kW)					0.42	0.71	0.96	1.21	0.75	1.26	1.68	2.05	2.39
R (ph-ph) (Ω)					36.8	10.5	6.30	4.20	12.7	4.08	2.10	1.50	1.03
L (ph-ph) (mH)					54.9	24.8	14.9	10.8	31.5	13.6	8.50	6.30	4.80
Rated speed 6000 (rpm)	K_t (Nm/A) = K_e (V/krpm) =	0.74 45.00	0.73 44.30	0.79 47.90	K_t (Nm/A) = 0.80 K_e (V/krpm) = 49.00								
Rated torque (Nm)		0.48	0.91	1.35	0.9	1.6	2.1	2.6	1.3	2.1	2.8	C/D	C/D
Stall current (A)		0.98	1.91	2.68	1.5	2.8	3.9	4.9	2.9	5.4	7.4		
Rated power (kW)		0.33	0.63	0.99	0.57	1.01	1.32	1.63	0.82	1.32	1.76		
R (ph-ph) (Ω)		30.0	11.4	8.0	15.0	5.00	2.66	1.90	5.45	1.82	1.05		
L (ph-ph) (mH)		67.3	33.1	25.7	24.0	10.6	6.80	4.80	14.1	6.00	3.80		

C/D Consult Drive Centre/Distributor

N/A Not available

The information contained in this specification is for guidance only and does not form part of any contract

	115U2					142U2					190U2							
	A	B	C	D	E	A	B	C	D	E	A	B	C	D	E	F	G	H
	3.5	6.6	9.4	12.4	15.3	5.7	10.8	15.3	19.8	23.4	9.6	21.8	31.1	41.1	50.6	58.7	66.0	73.2
	10.5	19.8	28.2	37.2	45.9	17.1	32.4	45.9	59.4	70.2	28.8	65.4	93.3	123.0	151.6	176.0	198.0	219.0
	14	26.4	37.6	49.6	61.2	22.8	43.2	61.2	79.2	93.6	N/A	N/A	N/A	N/A	N/A	N/A	N/A	N/A
	4.4	6.7	9.0	11.4	13.8	9.0	15.6	22.2	28.8	35.4	29.9	48.7	67.5	86.4	105.0	123.1	142.9	161.8
	9.5	11.8	14.1	16.6	18.9	23.3	29.9	36.5	43.1	49.7	75.1	93.9	112.7	131.6	150.2	168.3	188.1	207.0
	175	185	198	217	241	213	217	275	301	365	217	240	241	242	281	319	476	632
	7.80	9.70	11.60	13.50	15.40	10.00	13.30	16.10	18.90	21.70	21.00	25.30	29.60	33.90	38.20	42.50	46.80	51.30
	9.00	10.90	12.80	14.70	17.20	12.20	15.00	17.80	19.60	23.40	23.00	27.30	31.60	35.90	40.20	44.50	48.80	53.10
	3.2	6.1	8.7	10.8	14.0	5.3	10.3	14.6	18.4	21.3	9.3	20.0	28.4	36.9	43.8	50.4	53.0	54.7
	1.5	2.8	4.0	5.2	6.4	2.4	4.5	6.4	8.3	9.8	4.0	9.1	13.0	17.2	21.1	24.5	27.5	30.5
	0.67	1.28	1.82	2.26	2.93	1.11	2.16	3.06	3.85	4.46	1.90	4.19	5.90	7.73	9.20	10.6	11.1	11.5
	27.8	8.55	4.55	2.96	2.17	12.5	3.60	2.10	1.35	0.98	6.15	1.80	0.83	0.56	0.39	0.33	0.30	0.23
	94.6	40.5	25.7	18.6	14.7	58.0	29.8	18.7	13.6	10.7	52.90	28.10	15.00	13.0	8.68	8.90	6.73	6.30
	3.0	5.5	8.1	10.4	12.6	4.9	9.0	12.2	15.8	18.0	8.7	19.2	25.0	33.0	34.0	35.0	36.0	36.8
	2.2	4.2	5.9	7.8	9.6	3.6	6.8	9.6	12.4	14.7	6.0	13.7	19.4	25.7	31.6	36.7	41.3	45.8
	0.94	1.73	2.54	3.27	3.96	1.54	2.83	3.83	4.96	5.65	2.73	6.03	7.85	10.4	10.7	11.0	11.3	11.6
	12.6	3.86	2.02	1.40	1.10	5.63	1.72	0.94	0.61	0.44	2.73	0.79	0.41	0.30	0.17	0.14	0.13	0.09
	43.1	18.6	11.4	8.60	7.40	31.0	13.3	8.30	6.10	4.80	23.50	13.20	7.35	6.11	3.86	3.60	2.99	2.46
	2.5	4.7	6.3	7.5	8.7	3.6	7.0	8.9	10.7	12.2	C/D	C/D	C/D	C/D	N/A	N/A	N/A	N/A
	3.0	5.5	7.9	10.4	12.8	4.8	9.0	12.8	16.5	19.5								
	1.05	1.97	2.64	3.14	3.64	1.51	2.93	3.73	4.48	5.11								
	6.91	2.14	1.16	0.73	0.57	3.12	1.00	0.53	0.35	0.24								
	23.5	10.2	6.60	4.70	3.90	17.6	7.50	4.70	3.60	2.70								
	2.2	4.0	C/D	C/D	N/A	2.9	4.5	C/D	C/D	N/A	N/A	N/A	N/A	N/A	N/A	N/A	N/A	N/A
	4.4	8.3				7.2	13.5											
	1.38	2.51				1.82	2.83											
	3.10	0.97				1.42	0.46											
	15.5	4.81				7.72	3.44											

Stall torque, rated torque and power relate to maximum continuous operation tested in a 20°C ambient at 12kHz drive switching frequency

All other figures relate to a 20°C motor temperature. Maximum intermittent winding temperature is 140°C

Control Techniques have an ongoing process of development and reserve the right to change the specification without notice

055-250 Unimotor Product Data

For 3 Phase VPWM drives 380- 480Vrms

$\Delta t = 100^{\circ}\text{C}$ winding 40°C maximum ambient

All data subject to +/-10% tolerance

Motor frame size (mm)		250U2							
Frame length		A	B	C	D	E	F	G	H
Continuous stall torque (Nm)		N/A	N/A	N/A	92.0	116.0	136.0	N/A	N/A
Standard (2) peak torque selection max (Nm)					276.0	348.0	408.0		
High (P) peak torque selection max (Nm)					N/A	N/A	N/A		
Standard inertia (kgcm ²)					279.0	342.0	404.0		
High inertia (kgcm ²)					C/D	C/D	C/D		
Winding thermal time const. (s)					439	486	608		
Standard motor weight unbraked (kg)					57.50	65.50	73.70		
Standard motor weight braked (kg)					68.5	76.5	84.5		
Speed 1000 (rpm)	$K_t \text{ (Nm/A)} =$ $K_e \text{ (V/krpm)} =$	$K_t \text{ (Nm/A)} = 5.4$ $K_e \text{ (V/krpm)} = 323.00$							
	Rated speed (rpm)				1000	1000	1000		
	Rated torque (Nm)				75.0	92.0	106.0		
	Stall current (A)				17.2	21.7	25.4		
	Rated power (kW)				7.90	9.60	11.1		
	R (ph-ph) (Ω)				0.61	0.48	0.34		
	L (ph-ph) (mH)				22.9	19.10	14.90		
Speed 1500 (rpm)	$K_t \text{ (Nm/A)} =$ $K_e \text{ (V/krpm)} =$	$K_t \text{ (Nm/A)} = 3.60$ $K_e \text{ (V/krpm)} = 216.00$							
	Rated speed (rpm)				1500	1500	1500		
	Rated torque (Nm)				67.0	76.0	84.0		
	Stall current (A)				25.8	32.5	38.1		
	Rated power (kW)				10.5	11.9	13.2		
	R (ph-ph) (Ω)				0.27	0.21	0.15		
	L (ph-ph) (mH)				10	8.60	6.60		
Speed 2000 (rpm)	$K_t \text{ (Nm/A)} =$ $K_e \text{ (V/krpm)} =$	$K_t \text{ (Nm/A)} = 2.70$ $K_e \text{ (V/krpm)} = 162.00$							
	Rated speed (rpm)				1500	1500	1500		
	Rated torque (Nm)				65.0	73.0	81.0		
	Stall current (A)				34.4	43.4	50.9		
	Rated power (kW)				10.2	11.5	12.7		
	R (ph-ph) (Ω)				0.15	0.1	0.08		
	L (ph-ph) (mH)				5.7	4.2	3.7		
Speed 2500 (rpm)	$K_t \text{ (Nm/A)} =$ $K_e \text{ (V/krpm)} =$	$K_t \text{ (Nm/A)} = 2.10$ $K_e \text{ (V/krpm)} = 129.00$							
	Rated speed (rpm)				1500	1500	1500		
	Rated torque (Nm)				62.0	70.0	77.0		
	Stall current (A)				43.0	54.2	63.6		
	Rated power (kW)				9.7	11	12.1		
	R (ph-ph) (Ω)				0.09	0.08	0.06		
	L (ph-ph) (mH)				3.5	3.1	2.6		

For the 250 motor frame size, resolver feedback is standard.

C/D Consult drive centre/Distributor

N/A Not available

The information contained in this specification is for guidance only and does not form part of any contract

Stall torque, rated torque and power relate to maximum continuous operation tested in a 20°C ambient at 12kHz drive switching frequency

All other figures relate to a 20°C motor temperature. Maximum intermittent winding temperature is 140°C

Control Techniques have an ongoing process of development and reserve the right to change the specification without notice

Standard (2) peak torque

Peak torque defined for a maximum period of 250ms, RMS 3000 rpm, $\Delta_{max} = 100^{\circ}\text{C}$, 40°C ambient.
SC = stall current

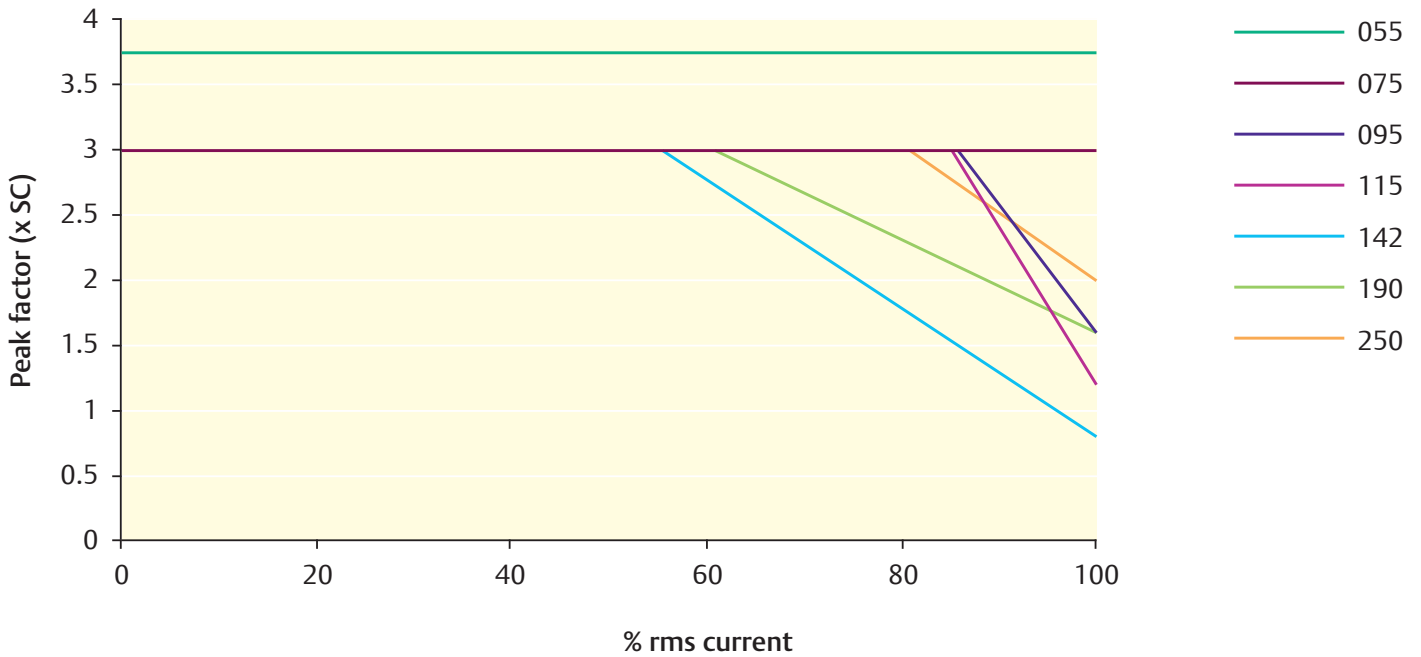

High (P) peak torque

Peak torque defined for a maximum period of 250ms, RMS 3000 rpm, $\Delta_{max} = 100^{\circ}\text{C}$, 40°C ambient.
SC = stall current

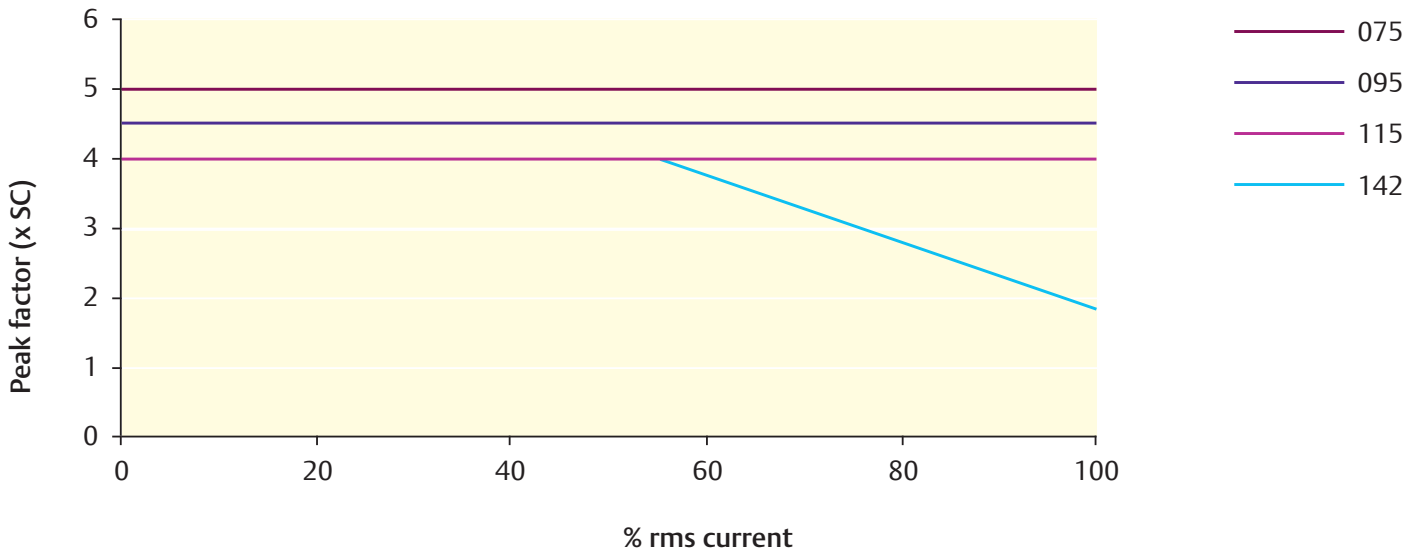

Dimensions (mm) Frame size 055

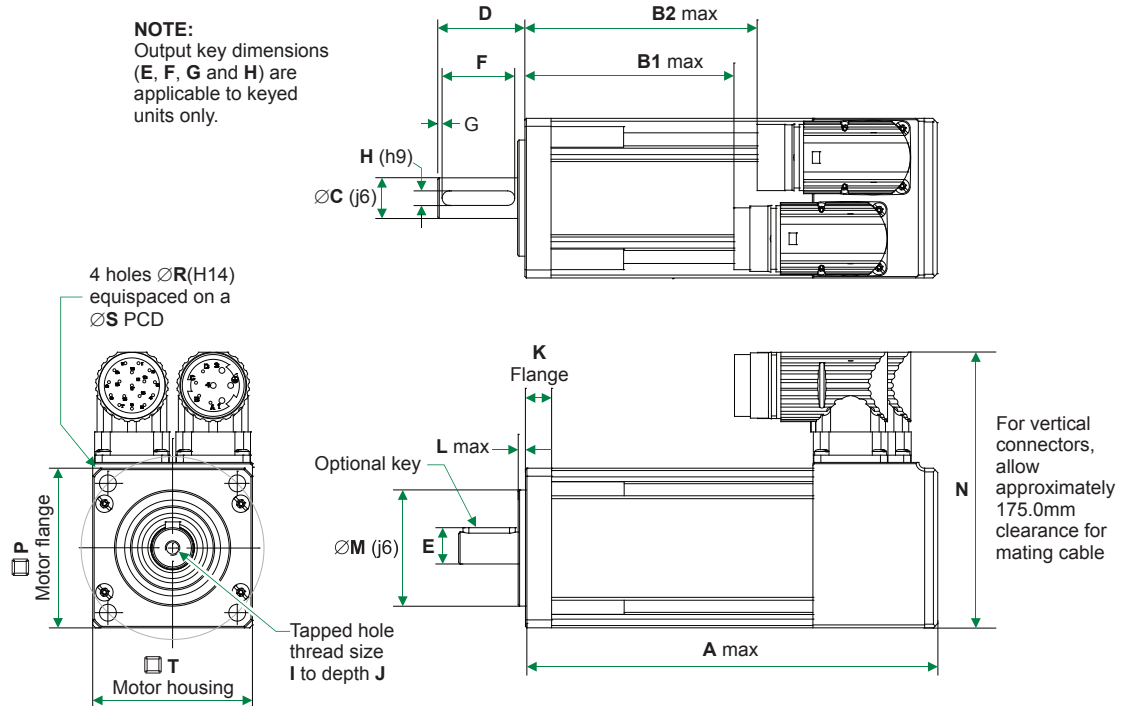

Standard motor dimension (mm) Note all dimensions shown are at nominal

	Unbraked length			Braked length			Flange thickness K	Register length L	Register diameter M (j6)	Overall height N	Flange square P	Fixing hole diameter R (H14)	Fixing hold PCD S	Motor housing T	Mounting bolts
	A	B1	B2	A	B1	B2									
055A	118.0	48.0	56.0	158.0	88.0	96.0	9.0	2.5	40.0	96.0	55.0	5.8	63.0	55.0	M5
055B	142.0	72.0	80.0	182.0	112.0	120.0									
055C	166.0	96.0	104.0	206.0	136.0	144.0									

Vertical connectors dimension (mm)

Note all dimensions shown are at nominal

	Unbraked length		Braked length		Power connector N	Signal connector N
	B1	B2	B1	B2		
055A	75.0	83.0	115.0	123.0	104.0	93.0
055B	99.0	107.0	139.0	147.0	104.0	93.0
055C	123.0	131.0	163.0	173.0	104.0	93.0

Shaft diameter (mm)

	Shaft diameter C (j6)	Shaft length D	Key height E	Key length F	Key to shaft end G	Key width H (h9)	Tapped hole thread size I	Tapped hole depth J
9.0 A Std	9.0	20.0	11.1	15.8	1.5	3.0	M4	10.0
11.0 B-C Std	11.0	23.0	13.4	18.8	1.2	4.0	M4	10.0
14.0 Max	14.0	30.0	16.9	25.8	1.2	5.0	M5	12.5

Optional connector height (mm)

C type	96.00
V type	105.0

Dimensions (mm) Frame size 075

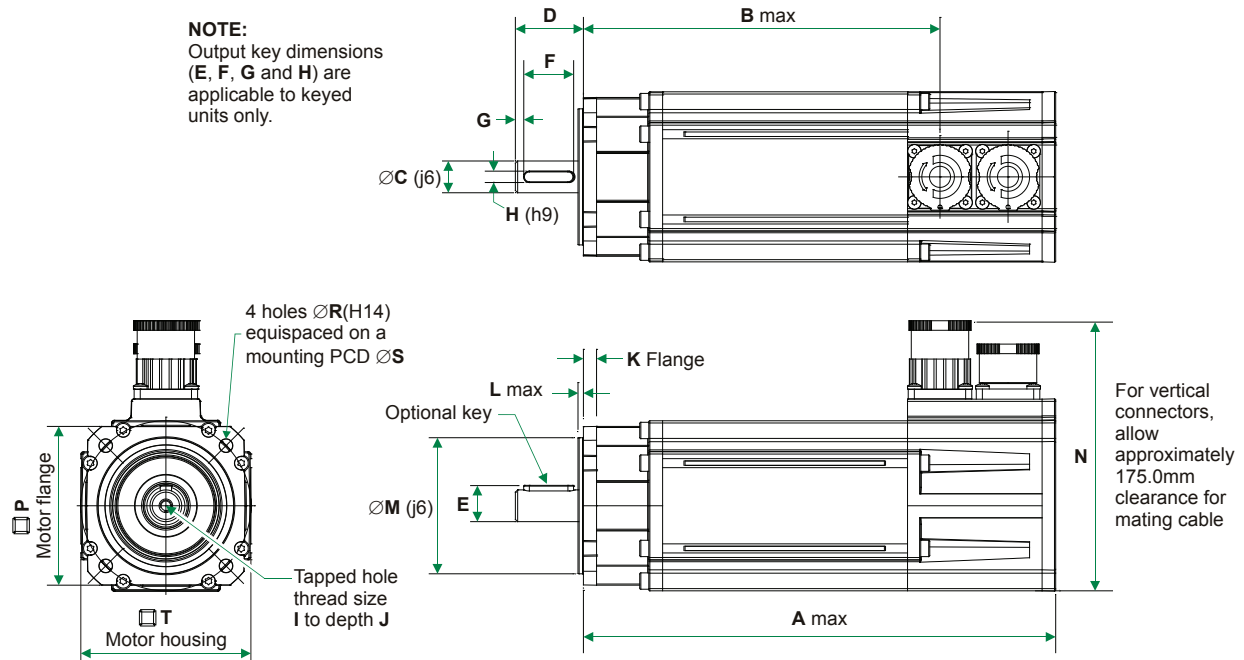

Standard motor dimension (mm) Note all dimensions shown are at nominal

	Unbraked length		Braked length		Flange thickness K (± 0.5)	Register length L (± 0.1)	Register diameter M (j6)	Overall height N (± 1.0)	Flange square P (± 0.1)	Fixing hole diameter R (H14)	Fixing hole PCD S (± 0.4)	Motor housing T (± 0.45)	Mounting bolts
	A (± 0.9)	B (± 1.0)	A (± 0.9)	B (± 1.0)									
075A	208.2	157.2	253.2	202.2	5.8	2.40	60.0	118.5	70.0	6.10	75.0	75.0	M5
075B	238.2	187.2	283.2	232.2									
075C	268.2	217.2	313.2	262.2									
075D	298.2	247.2	343.2	292.2									

Optional flat flange motor dimensions (mm)

	Unbraked length		Braked length	
	A (± 0.9)	B (± 1.0)	A (± 0.9)	B (± 1.0)
075A	192.6	141.6	237.6	186.6
075B	222.6	171.6	267.6	216.6
075C	252.6	201.6	297.6	246.6
075D	282.6	231.6	327.6	276.6

Optional flange dimensions (mm)

Flange square P (± 0.1)	Fixing hole PCD S (± 0.4)	Register diameter M (j6)	Fixing hole diameter R (H14)
70.0	66.7 - 75.0	60.0	6.10
70.0	75.0 - 80.0	60.0	6.10
80.0	85.0	70.0	7.00

Shaft diameter (mm)

	Shaft diameter C (j6)	Shaft length D (± 0.45)	Key height E (± 0.4)	Key length F (± 0.25)	Key to shaft end G (± 1.1)	Key width H (h9)	Tapped hole thread size I	Tapped hole depth J (± 0.4)
11.0 A Std	11.0	23.0	12.5	14.0	3.6	4.0	M4 x 0.4	11.0
14.0 B-D Std	14.0	30.0	15.9	22.0	3.6	5.0	M5 x 0.8	13.5
19.0 Max	19.0	40.0	21.4	32.0	3.6	6.0	M6 x 1.0	17.0

Optional connector height (mm)

Connection type	Overall height
	N (± 1.0)
A	118.0
B	126.0
C	126.0

Dimensions (mm) Frame size 095

NOTE:
Output key dimensions
(E, F, G and H) are
applicable to keyed
units only.

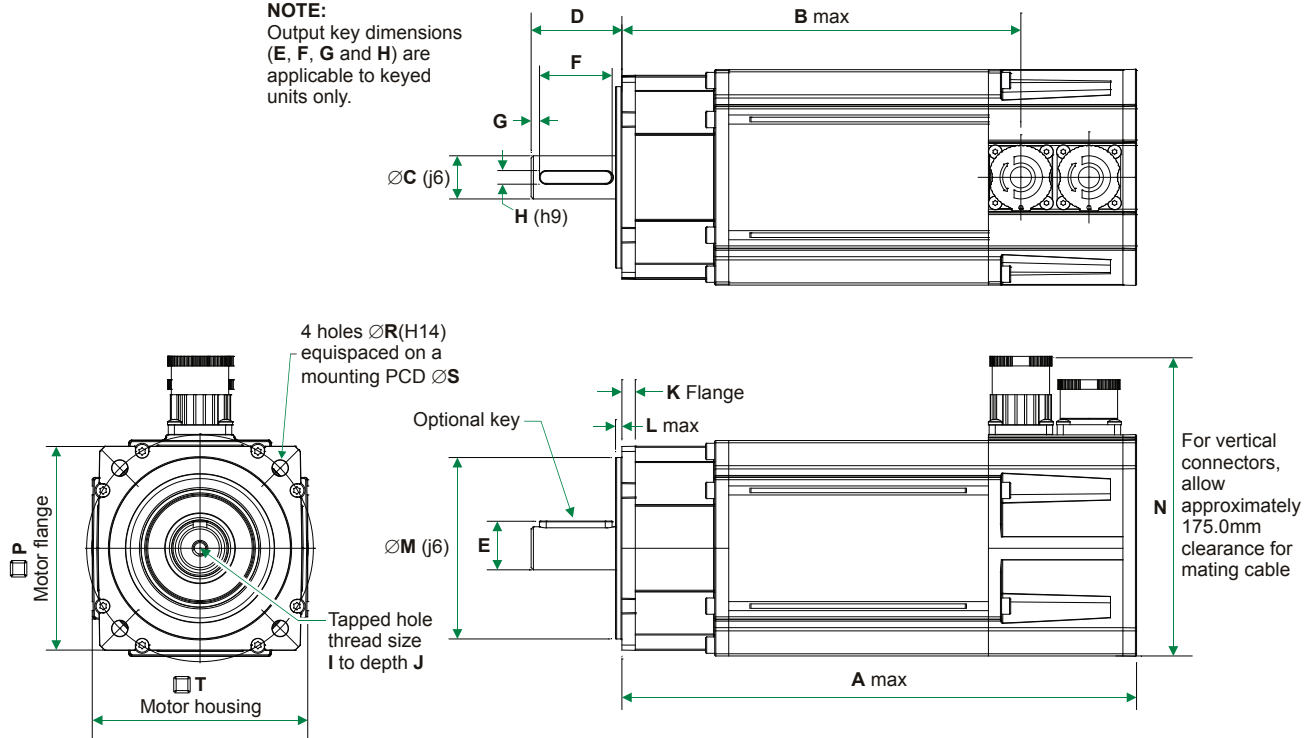

Standard motor dimension (mm) Note all dimensions shown are at nominal

	Unbraked length		Braked length		Flange thickness K (± 0.5)	Register length L (± 0.1)	Register diameter M (j6)	Overall height N (± 1.0)	Flange square P (± 0.1)	Fixing hole diameter R (H14)	Fixing hole PCD S (± 0.4)	Motor housing T (± 0.6)	Mounting bolts
	A (± 0.9)	B (± 1.0)	A (± 0.9)	B (± 1.0)									
095A	226.9	175.9	271.9	220.9	5.9	2.80	80.0	131.5	90.0	7.0	100.0	95.0	M6
095B	256.9	205.9	301.9	250.9									
095C	286.9	235.9	331.9	280.9									
095D	316.9	265.9	361.9	310.9									
095E	346.9	295.9	391.9	340.9									

Optional flat flange motor dimensions (mm)

	Unbraked length		Braked length	
	A (± 0.9)	B (± 1.0)	A (± 0.9)	B (± 1.0)
095A	201.8	150.8	246.8	195.8
095B	231.8	180.8	276.8	225.8
095C	261.8	210.8	306.8	255.8
095D	291.8	240.8	336.8	285.8
095E	321.8	270.8	366.8	315.8

Optional flange dimensions (mm)

Flange square P (± 0.1)	Fixing hole pcd S (± 0.4)	Register diameter M (j6)	Flange thickness K (± 0.5)	Fixing hole diameter R (H14)
90.0	98.43	73.0	6.8	7.0
105.0	115.0	95.0	6.8	10.0

Shaft diameter (mm)

	Shaft diameter C (j6)	Shaft length D (± 0.45)	Key height E (± 0.4)	Key length F (± 0.25)	Key to shaft end G (± 1.1)	Key width H (h9)	Tapped hole thread size I	Tapped hole depth J (± 0.4)
	14.0 A Std	14.0	30.0	15.9	22.0	3.6	5.0	M5 x 0.8
19.0 B-E Std	19.0	40.0	21.4	32.0	3.6	6.0	M6 x 1.0	17.0
22.0 Max	22.0	50.0	24.4	40.0	4.6	6.0	M8 x 1.25	20.0

Optional connector height (mm)

Connection type	Overall height N (± 1.0)
	A
B	139.0
C	139.0

Dimensions (mm) Frame size 115

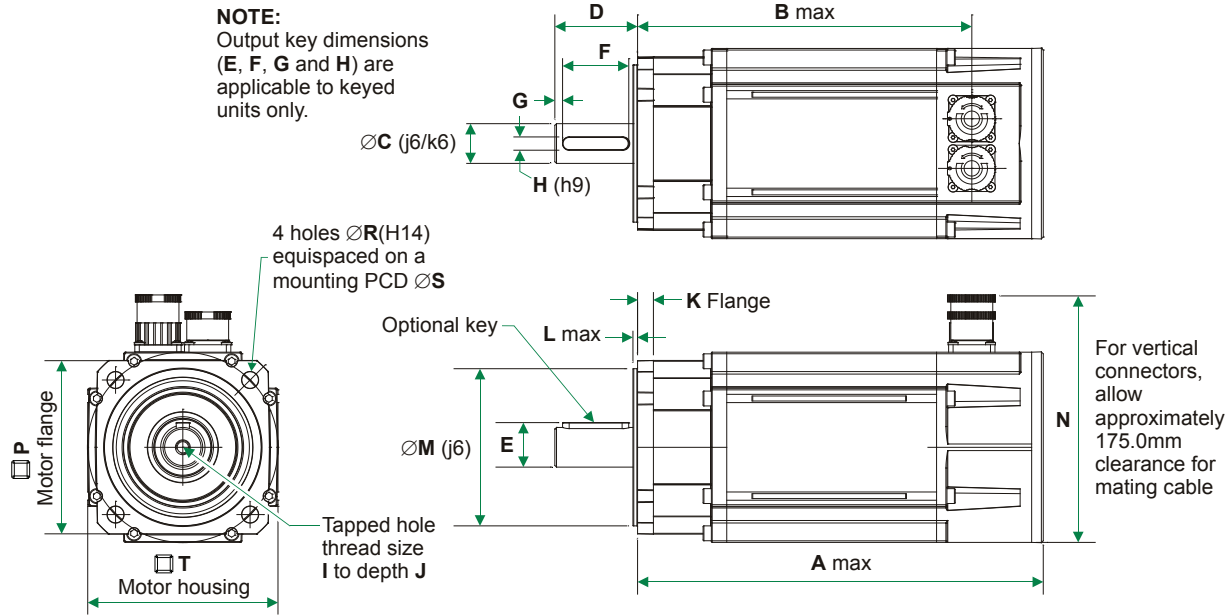

Standard motor dimension (mm) Note all dimensions shown are at nominal

	Unbraked length		Braked length		Flange thickness	Register length	Register diameter	Overall height	Flange square	Fixing hole diameter	Fixing hole PCD	Motor housing	Mounting bolts
	A (± 0.9)	B (± 1.0)	A (± 0.9)	B (± 1.0)									
115A	245.2	202.	290.2	247.0	9.6	2.80	95.0	149.0	105.0	10.0	115.0	115.0	M8
115B	275.2	232.0	320.2	277.0									
115C	305.2	262.0	350.2	307.0									
115D	335.2	292.0	380.2	337.0									
115E	365.2	322.0	410.2	367.0									

Optional flat flange motor dimensions (mm)

	Unbraked length		Braked length	
	A (± 0.9)	B (± 1.0)	A (± 0.9)	B (± 1.0)
115A	214.4	171.2	259.4	216.2
115B	244.4	201.2	289.4	246.2
115C	274.4	231.2	319.4	276.2
115D	304.4	261.2	349.4	306.2
115E	334.4	291.2	379.4	336.2

Optional flange dimensions (mm)

Flange square	Fixing hole PCD	Register diameter	Fixing hole diameter
P (± 0.2)	S (± 0.4)	M (j6)	R (H14)
130.0	130.0	110.0	10.0
130.0	125.7 – 130.0	110.0	10.0
130.0	130.0 – 145.0	110.0	10.0

Shaft diameter (mm)

	Shaft diameter	Shaft length	Key height	Key length	Key to shaft end	Key width	Tapped hole thread size	Tapped hole depth
	C (j6)	D (± 0.45)	E (± 0.4)	F (± 0.25)	G (± 1.1)	H (h9)	I	J (± 0.4)
19.0 A-C Std	19.0	40.0	21.4	32.0	3.6	6.0	M6 x 1.0	17.0
22.0 Opt	22.0	50.0	24.4	40.0	4.6	6.0	M8 x 1.25	20.0
24.0 D-E Std	24.0	50.0	26.9	40.0	4.6	8.0	M8 x 1.25	20.0
28.0 Opt	28.0	60.0	30.9	50.0	4.6	8.0	M10 x 1.5	23.0
32.0 Max	32.0 (K6)	80.0	34.9	70.0	4.6	10.0	M12 x 1.75	29.0

Optional connector height (mm)

Connection type	Overall height
	N (± 1.0)
A	149.0
B	156.5
C	156.5

Dimensions (mm) Frame size 142

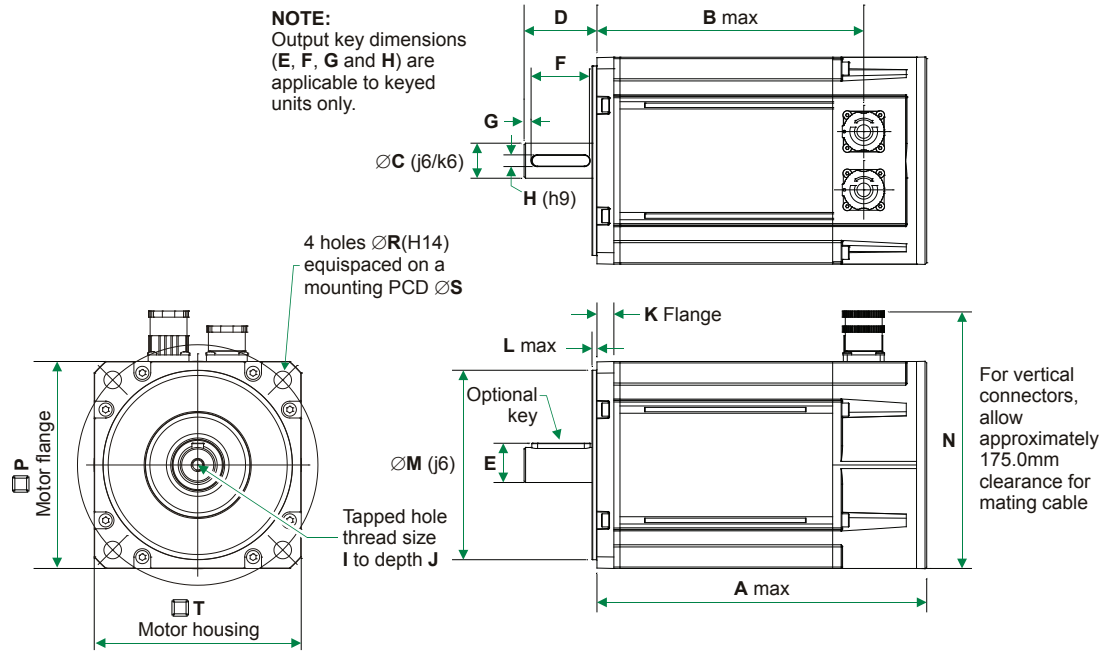

Standard motor dimension (mm) Note all dimensions shown are at nominal

	Unbraked length		Braked length		Flange thickness	Register length	Register diameter	Overall height vertical	Flange square	Fixing hole diameter	Fixing hole PCD	Motor housing	Mounting bolts
	A (± 0.9)	B (± 1.0)	A (± 0.9)	B (± 1.0)									
142A	226.2	183.0	271.2	228.0	11.6	3.4	130.0	176.0	142.0	12.0	165.0	142.0	M10
142B	256.2	213.0	301.2	258.0									
142C	286.2	243.0	331.2	288.0									
142D	316.2	273.0	361.2	318.0									
142E	346.2	303.0	391.2	348.0									

Optional motor flange dimensions (mm)

	Unbraked length		Braked length	
	A (± 0.9)	B (± 1.0)	A (± 0.9)	B (± 1.0)
142A	276.4	233.2	321.4	278.2
142B	306.4	263.2	351.4	308.2
142C	336.4	293.2	381.4	338.2
142D	366.4	323.2	411.4	368.2
142E	396.4	353.2	441.4	398.2

Optional connector height (mm)

Connection type	Overall height
	N (± 1.0)
A	176.0
B	183.5
C	183.5

Optional flange dimensions (mm)

Flange square	Fixing hole pcd	Register diameter	Flange thickness	Fixing hole diameter
P (± 0.2)	S (± 0.1)	M (± 0.1)	K (± 0.5)	R (H14)
140.0	149.23	114.3	11.5	12.0

Shaft diameter (mm)

	Shaft diameter	Shaft length	Key height	Key length	Key to shaft end	Key width	Tapped hole thread size	Tapped hole depth
	C (± 0.1)	D (± 0.45)	E (± 0.4)	F (± 0.25)	G (± 1.1)	H (h9)	I	J (± 0.4)
22.0 Opt	22.0	50.0	24.4	40.0	4.6	6.0	M8 x 1.25	20.0
24.0 A-E Std	24.0	50.0	26.9	40.0	4.6	8.0	M8 x 1.25	20.0
28.0 Opt	28.0	60.0	30.9	50.0	4.6	8.0	M10 x 1.5	23.0
32.0 Max	32.0 (K6)	80.0	34.9	70.0	4.6	10.0	M12 x 1.75	29.0

Dimensions (mm) Frame size 190

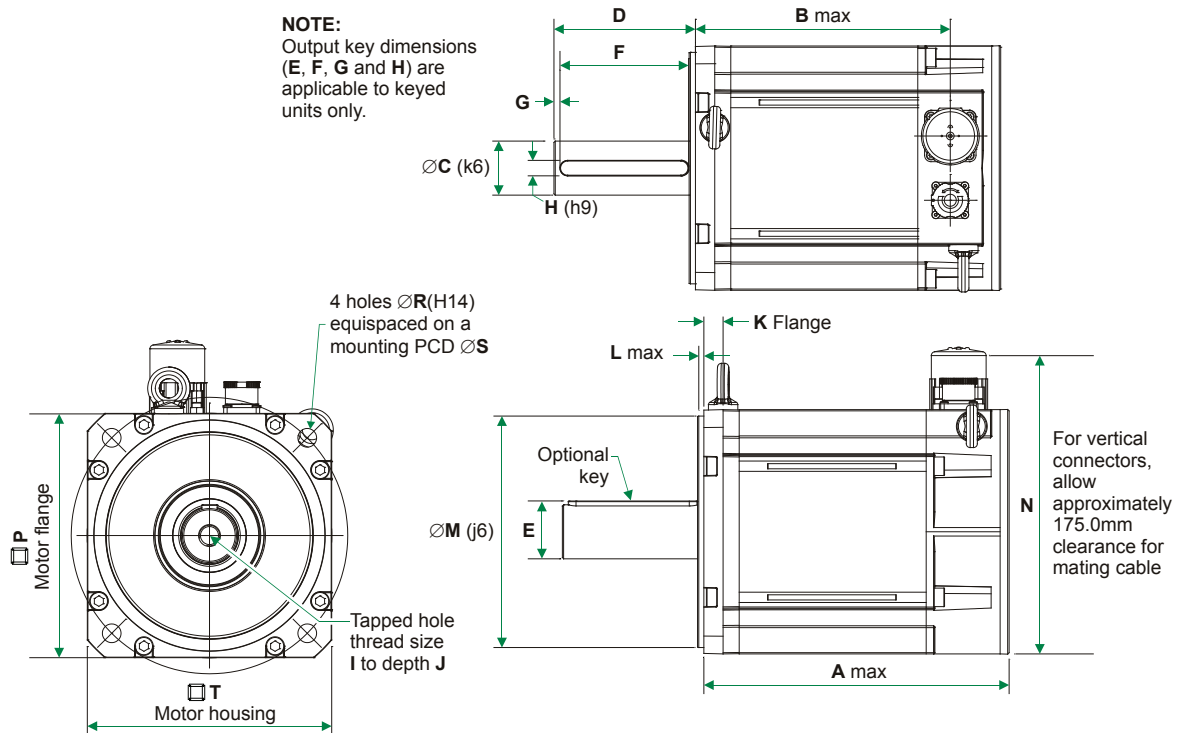

Standard motor dimension (mm) Note all dimensions shown are at nominal

	Unbraked length		Braked length		Flange thickness K (± 0.5)	Register length L (± 0.1)	Register diameter M (j6)	Overall height N (± 1.0)	Flange square P (± 0.2)	Fixing hole diameter R (H14)	Fixing hole PCD S (± 0.4)	Motor housing T (± 1.5)	Mounting bolts
	A (± 0.9)	B (± 1.0)	A (± 0.9)	B (± 1.0)									
190A	237.4	198.2	318.2	279.0	15.0	3.90	180.0	232.0	190.0	14.5	215.0	190.0	M12
190B	264.3	225.1	345.2	306.0									
190C	291.3	252.1	372.1	332.9									
190D	318.2	279.0	399.1	359.9									
190E	345.2	306.0	426.0	386.8									
190F	372.1	332.9	453.0	413.8									
190G	399.1	359.9	479.9	440.7									
190H	426.0	386.8	506.9	467.7									

Optional connector height (mm)

Connection type	Overall height
	N (± 1.0)
A	245.0
B	252.5
C	252.5

Shaft diameter (mm)

	Shaft diameter	Shaft length	Key height	Key length	Key to shaft end	Key width	Tapped hole thread size	Tapped hole depth
	C (j6)	D (± 0.45)	E (± 0.4)	F (± 0.25)	G (± 1.1)	H (h9)	I	J (± 0.4)
28.0 Opt	28.0	60.0	30.9	50.0	4.6	8.0	M10 x 1.5	23.0
32.0 A-H Std	32.0 (k6)	80.0	34.9	70.0	4.6	10.0	M12 x 1.75	29.0
38.0 Opt	38.0 (k6)	80.0	40.9	70.0	4.6	10.0	M12 x 1.75	29.0
42.0 Max	42.0 (k6)	110.0	45.0	100.0	4.6	12.0	M16 x 2.0	37.0

Dimensions (mm) Frame size 250

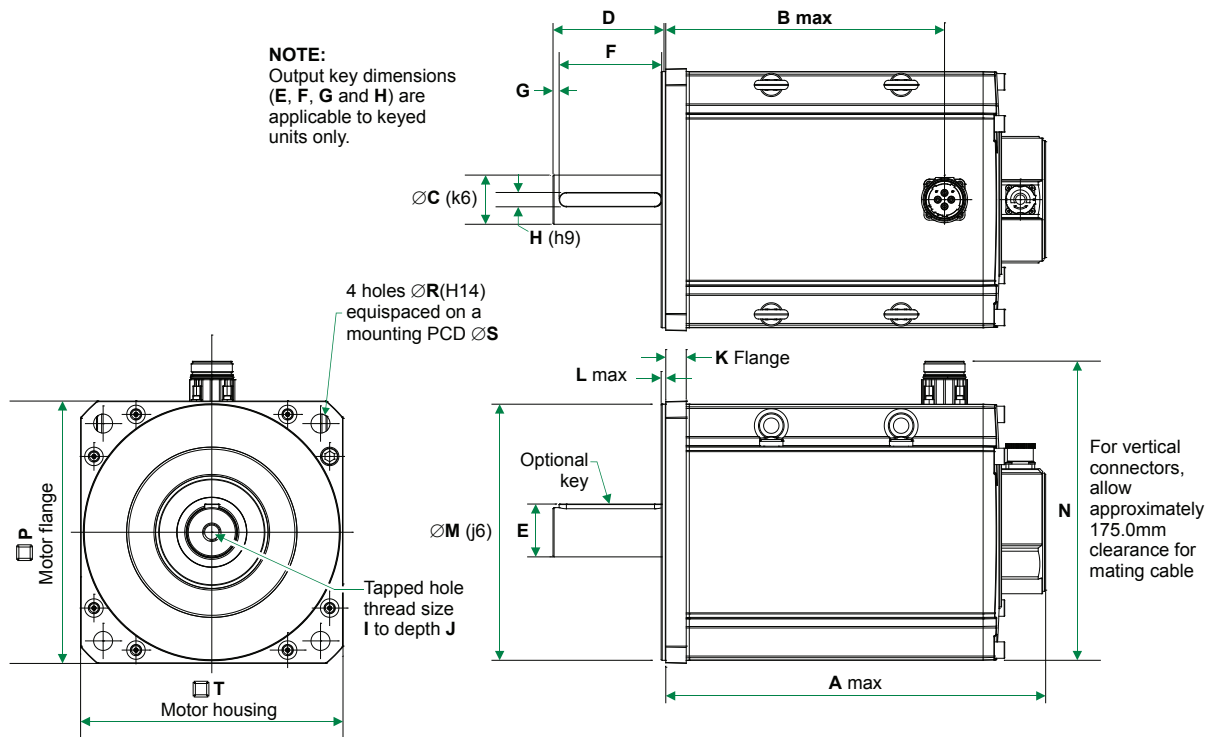

Standard motor dimension (mm) Note all dimensions shown are at nominal

	Unbraked length		Braked length		Flange thickness K (± 0.5)	Register length L (± 0.1)	Register diameter M (j6)	Overall height N (± 1.0)	Flange square P (± 0.6)	Fixing hole diameter R (H14)	Fixing hole PCD S (± 0.4)	Motor housing T (± 1.0)	Mounting bolts
	A (± 1.3)	B (± 1.0)	A (± 1.3)	B (± 1.0)									
250D	370.7	273.7	442.5	345.5	20.0	4.50	250.0	312.5	256.0	18.5	300.0	249.5	M16
250E	400.7	303.7	472.5	375.5									
250F	430.7	333.7	502.5	405.5									

Shaft diameter (mm)

	Shaft diameter	Shaft length	Key height	Key length	Key to shaft end	Key width	Tapped hole thread size	Tapped hole depth
	C (k6)	D (± 0.45)	E (± 0.4)	F (± 0.25)	G (± 1.1)	H (h9)	I	J (± 0.4)
38.0 Opt	38.0	80.0	41.0	70.0	4.6	10.0	M12 x 1.75	29.0
42.0 Opt	42.0	110.0	45.0	100.0	6.0	12.0	M16 x 2.0	37.0
480 D-F Std	48.0	110.0	51.5	100.0	6.0	14.0	M16 x 2.0	37.0

Motor selection

- Motor derating** Any adverse operating conditions require that the motor performance be derated. These conditions include; ambient temperature above 40°C, motor mounting position, drive switching frequency or the drive being oversized for the motor.
- Ambient temperatures** The ambient temperature around the motor must be taken into account. For ambient temperatures above 40°C the torque must be derated using the following formula as a guideline. (Note: Only applies to 2000/3000rpm motors and assumes copper losses dominate)
- $$\text{New derated torque} = \text{Specified torque} \times \sqrt{1 - (\text{Ambient temperature} - 40) / 100}$$
- For example with an ambient temperature of 76°C the new derated torque will be 0.8 x specified torque.
- Mounting arrangements** The motor torque must be derated if the motor mounting surface is heated from an external source, such as a gearbox. The motor is connected to a poor thermal conductor. The motor is mounted with the connectors on the side or vertical. The motor is in a confined space with restricted air flow.
- Drive switching frequency** Most Unidrive SP and Digitax ST nominal current ratings are reduced for the higher switching frequencies. See the appropriate drive manual for details.

See the table below for the motor derate factors. These figures are for guidance only.

(Note: Only applies to motors up to 3000rpm for frame sizes 055 to 190 and 1500rpm for frame size 250. Assumes copper losses dominate on all frame sizes.)

Motor derate factors

Switching frequency	Motor type/frame									
	055	075	095	115		142		190		250
	A-C	A-D	A-E	A-C	D-E	A-C	D-F	A-B	C-H	D-F
3kHz	0.84	0.93	0.88	0.89	0.84	0.87	0.81	0.98	N/A	0.88
4kHz	0.87	0.94	0.91	0.91	0.87	0.91	0.86	0.99	0.55	0.90
6kHz	0.90	0.95	0.93	0.93	0.90	0.94	0.89	0.99	0.77	0.94
8kHz	0.95	0.98	0.97	0.97	0.95	0.97	0.96	1	0.90	0.80
12/16kHz	1	1	1	1	1	1	1	1	1	1

- Thermal test conditions** The performance data shown has been recorded under the following conditions: Ambient temperature 20°C, with the motor mounted on a thermally isolated aluminum plate as shown below.

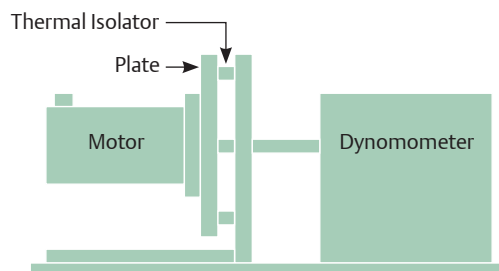

Motor type/frame	Aluminium heatsink plate
055	110 x 110 x 27mm
075-095	250 x 250 x 15mm
115-142	350 x 350 x 20mm
190	500 x 500 x 20mm
250	500 x 500 x 20mm

- Thermal protection** Thermistor protection (145°C for 075-250 frame sizes and 150°C for 055 frame size) is built into the motor windings and gives an indication of serious overheating problems. The installer must connect the thermistor to the drive. Failure to do so will invalidate the motor warranty in respect of a burnt out winding.

- Environmental conditions** Any liquids or gases that may come into contact with the motor must be checked to ensure compliance with the appropriate international standards.

Motor selection

Low voltage directive 2006/95/EC

Note: Machinery Directive 89/392/EEC amended to 98/37/EC Low Voltage Directive 73/23/EEC superseded by directive 2006/95/EC on 16/01/07, which specifically excludes electric motors.

EN 60034	General requirements for rotating electrical machinery
EN 60034-1	Duty: S1 Continuous Storage: -15°C to +40°C Operating: Min ambient 0°C; max ambient 40°C Less than 1000m altitude Relative humidity: 90% non condensing
EN 60034-5	Degree of Ingress protection: IP65 (when mounted and connected)
EN 60034-6	Method of cooling: free circulation, free convection
EN 60034-7	Flange mounted: horizontally or vertically
EN 60034-8	Terminal markings: U V W
EN 60034-11	Thermal protection: PTC thermistor, 145°C on 075-250 motors Thermal protection: PTC thermistor, 150°C on 055 motors
EN 60034-18	Insulation system: Class F 600V, UL number E214439 on 075-250 motors Insulation system: Class F 600V, UL number E68554 on 055 motors
EN 60034-25	The design and performance of motors specifically designed for converter supply
EN 60072	Dimensions and output for rotating electrical machines
EN 60072-1	Type N (Customer variants)
ISO1940-1	Balancing: to G6.3, (ISO8821 half key convention)

Standard brake specification

Motor frame	Supply volts	Input power	Static torque		Release time	Moment of inertia	Backlash
			Standard brake (01)	High energy brake (05)			
Size	Vdc	Watts	Nm	Nm	ms norm	kgcm ² *	Degrees**
055	24	6.3	1.8	N/A	22	0.03	0.75
075	24	6.3	2	2.2	22	0.07	1.03
095	24	16	11	12.2	60	0.39	0.94
115	24	16	11	12.2	60	0.44	0.56
142	24	19.5	18	22	75	0.54	0.56
190 (A-D)	24	25	38	42	95	3.07	0.77
190 (E-H)	24	25	60	67	120	4.95	0.77
250	24	62	N/A	135	252	16.37	0.77

*Note 1 kgcm² = 1x10⁻⁴kgm² **Backlash figure will increase with time

- The brakes are intended for parking duty and are not for dynamic or safety use
- Refer to your Drive Centre or Distributor if your application requires dynamic braking in emergency conditions
- To provide protection to the brake control circuit it is recommended that a diode is connected across the output terminals of the solid state or relay contacts devices
- Larger torque brakes are available as an option. Please contact your Drive Centre or Distributor for details
- Figures are shown at 20°C brake temperature. Apply the derate factor of 0.7 to the standard brake torque figures if motor temperature is above 100°C. The derate factor does not apply to the high energy brake
- The brake will engage when power is removed

Feedback

Feedback device part number code	Feedback type	Manufacturer and product code	Encoder supply voltage ¹	Sincos cycles or incremental pulses per revolution	Resolution available to position loop ^{2&3}
055 motors					
AR	Resolver	LTN	7V	1	Medium
		RE-15	Excitation 5kHz		16384 (14 bit)
		Hengstler			Medium
KP	Incremental Encoder	F14	5V	1024	4096 (12 bit)
MP				2048	8192 (13 bit)
CP				4096	16384 (14 bit)
		Renco			Medium
KR	Incremental Encoder	R35i	5V	1024	4096 (12 bit)
MR				2048	8192 (13 bit)
		Heidenhain			Medium
EM (Multi-turn)	Inductive Absolute Encoder	EQI1130	5V	16	2.62x10 ⁵ (18 bits)
FM (Single turn)		ECI1118			
		Sick/Stegmann			Medium
TL (Multi-turn)	Sincos Optical Encoder	SKM36	8V	128	1.31x10 ⁵ (17 bit)
UL (Single turn)		SKS36			
		Heidenhain			Medium
TM (Multi-turn)	Inductive Absolute Encoder	EQN1125	3.6 - 14V	512	5.24x10 ⁵ (19bit)
UM (Single turn)		ECN1113			
075-250 motors					
AE	Resolver	API Harrowe	6 V rms	1	Medium
		Size 21	Excitation 6kHz		16384 (14 bit)
		SICK			Medium
CA	Incremental Encoder	CDD50	5V	4096	16384 (14 bit)
MA				2048	8192 (13 bit)
KA				1024	4096 (12 bit)
		Heidenhain			Medium
EC (Multi-turn)	Inductive Absolute Encoder	EQ11331	7 - 10V	32	Absolute position 524288 (19 bits)
FC (Single turn)		EC11319			
		SICK			High
RA (Multi-turn)	Sincos Optical Encoder	SRM50	7 - 12V	1024	1.04x10 ⁶
SA (Single turn)		SRS50			(20 bits)
		Heidenhain			Very High
EB (Multi-turn)	Optical Absolute Encoder	EQN1325	3.6 - 14V	2048	2.08x10 ⁶
FB (Single turn)		ECN1313			(21 bits)

Notes:

- 1) The output from the resolver is an analogue output. The resolution is determined by the analogue to digital converter used. The value shown is when the resolver is used in conjunction with the SM-Resolver.
- 2) The sin and cosine outputs from the Sincos optical encoders are analogue outputs. With Unidrive  and Digitax ST the resolutions quoted above are when the encoder type is set to either SC Endat or SC Hiper depending on the encoder.
- 3) The information is supplied by the feedback device manufacturer and relates to it as a standalone device. The values may change when mounted into the motor and connected to a drive. These values have not been verified by CT Dynamics.

Resolver

A passive wound device consisting of a stator and rotor elements excited from an external source, such as a resolver module, the resolver produces two output signals that correspond to the sine and cosine angle of the motor shaft. This is a robust absolute device of low accuracy, capable of withstanding high temperature and high levels of vibration. Positional information is absolute within one turn - i.e. position is not lost when the drive is powered down.

Incremental Encoder

An electronic device using an optical disc. The position is determined by counting steps or pulses. Two sequences of pulses in quadrature are used so the direction sensing may be determined and 4 x (pulses per rev) may be used for resolution in the drive. A marker pulse occurs once per revolution and is used to zero the position count. The encoder also provides commutation signals, which are required to determine the absolute position during the motor phasing test. This device is available in 4096, 2048 and 1024 ppr version. Positional information is non absolute - i.e. position is lost when the drive is powered down.

Sincos/Absolute Encoders

Types available are: Optical or Inductive - which can be single or multi-turn.





1) Optical: An electronic device using an optical disc. An absolute encoder with high resolution that employs a combination of absolute information, transmitted via a serial link, and sine/cosine signals with incremental techniques.

2) Inductive: An electronic device using inductively coupled PCB's. An absolute encoder with medium resolution that employs a combination of absolute information, transmitted via a serial link,

and sine/cosine signals with incremental techniques. This encoder can be operated with the drive using either sine/cosine or absolute (serial) values only. Electronic nameplating is available on both these types of encoders, and allows quick set-up times as the motor information is stored on board the encoder (075-250 motor only). Positional information is absolute within one turn - i.e. position is not lost when the drive is powered down.











Multi-turn: As previous but with extra gear wheels included so that the output is unique for each shaft position and the encoder has the additional ability to count complete turns of the motor shaft up to 4096 revolutions. Positional information is absolute within 4096 turns - i.e. position is not lost when the drive is powered down.

Cable information

PS	B	A		A	A	015	
Cable type	Jacket	Phase & ground: conductor size		Connection details drive end		Connection details motor end	Cable length
PS= Power (Standard)	B = PUR	G = 1.5mm ²	16A	A = Unidrive (Size 1-2) Ferrules		A = 055-142 Unimotor  power connector	Min = 002 (2m)
PB = Power (with brake)		A = 2.5mm ²	22A	B = Unidrive (Size 3-4) Ring terminals			Max = 100
		B = 4.0mm ²	30A	C = 6 way power extension connector (055-142 Unimotor  male pins)		B = 190-250 Unimotor  power connector	
		C* = 6.0mm ²	39A	F = Unidrive  (1-2) Ferrules			J = 250 hybrid ferrules
		D* = 10.0mm ²	53A	G = Unidrive  (3-4) Ring terminals		X = Cut end	
		E* = 16.0mm ²	70A	H = Digitax ST and SP0			
				X = Cut end			

* Ring terminals for Drive studs only

Cable type	PS for motor without brakes, PB for motors with brake.
Jacket	B is for a PUR sheath and is the standard selection.
Conductor size	Select the conductor size according to the motors STALL CURRENT. Cables of 6mm ² and above will be fitted with ring terminals only. Ratings are for individual cables (not lashed together) in free air temperature up to 40°C - make allowances as appropriate.
Connection detail drive end	Select the correct drive end connection for the drive in use.
Connection detail motor end	Select the correct motor end connection for the motor in use.
Length	Numbers represent the required cable length in metres.

SI	B	A	A	A	015
Cable type	Jacket	Special options		Connection details motor end	Cable length
SI = Incremental Encoder	B = PUR	A = Standard cable		A = Unimotor  Encoder connector	Min = 002 (2m)
SR = Resolver		E = Twisted screened SS cable		B = Unimotor  Resolver connector	Max = 100* 10m for SIBL
SS = Sin/Cos Encoder		L = 8.5mm dia SI cable		C = Unimotor  Sin/Cos connector (Sick Stegmann)	
Connection details drive end				E = 17 way extension connector	
A = Digitax ST/Unidrive  /Epsilon EP Encoder 15 pin connector				F = 90° Unimotor  Encoder connector	
B = Resolver / Sin/Cos Ferrules				G = 90° Unimotor  Resolver connector	
F = Epsilon Encoder 26 pin connector				H = 90° Unimotor  Sin/Cos connector (Sick Stegmann)	
G = Extension connector male pins				N = Unimotor  Sin/Cos connector (Heidenhain)	
H = Unidrive  Sin/Cos 15 pin connector				O = 90° Unimotor  Sin/Cos connector (Heidenhain)	
X = Cut end				X = Cut end	

* 100m on incremental only if +5V tolerance can be maintained

Cable type	Choose the cable type to match the feedback device.
Jacket	B is for a PUR sheath and is the standard selection.
Special options	A is for standard cable. L is for the low cost 8.5mm incremental cable.
Connection detail drive end	Select the correct drive end connection for the drive in use.
Connection detail motor end	Select the correct motor end connection for the motor feedback device in use.
Length	Numbers represent the required cable length in metres.

Motor connector details

Power plug

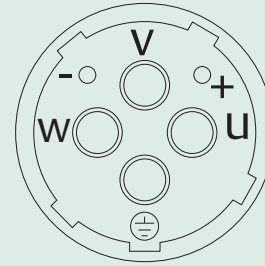
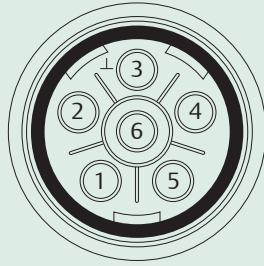

	055 -142 with brake	055 -142 without brake		190 -250 with brake	190 -250 without brake
Pin	Function	Function	Pin	Function	Function
1	Phase U (R)	Phase U (R)	U	Phase U (R)	Phase U (R)
2	Phase V (S)	Phase V (S)	V	Phase V (S)	Phase V (S)
3	Ground	Ground	⊕	Ground	Ground
4	Phase W (T)	Phase W (T)	W	Phase W (T)	Phase W (T)
5	Brake		+	Brake	
6	Brake		-	Brake	
Shell	Screen	Screen	Shell	Screen	Screen

Signal plug

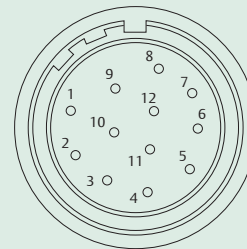
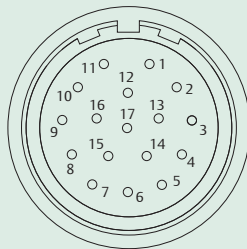

	Incremental encoder (KP, MP, CP, CA, MA)	Heidenhain Sin/Cos encoders (EM, FM, EC, FC, EB, FB)	Resolver (AE, AR)	Sick Stegmann Sin/Cos encoders (TL, UL, RB, SB)
Pin	Function	Function	Function	Function
1	Thermistor	Thermistor	Excitation High	REF Cos
2	Thermistor	Thermistor	Excitation Low	+ Daten
3		Screen (Optical encoder only)	Cos High	- Daten
4	S1		Cos Low	+ Cos
5	S1 Inverse		Sin High	+Sin
6	S2		Sin Low	REF Sin
7	S2 Inverse		Thermistor	Thermistor
8	S3	+ Clock	Thermistor	Thermistor
9	S3 Inverse	- Clock		Screen
10	Channel A	+ Cos		0 Volts
11	Index	+ Data		-
12	Index Inverse	- Data		+ 8V
13	Channel A Inverse	- Cos		
14	Channel B	+ Sin		
15	Channel B Inverse	- Sin		
16	+5 V	+ 8V		
17	0 Volts	0 Volts		
Body	Screen	Screen		Screen

Control Techniques Drive & Application Centres

AUSTRALIA
Melbourne Application Centre
T: +613 973 81777
controltechniques.au@emerson.com

Sydney Drive Centre
T: +61 2 9838 7222
controltechniques.au@emerson.com

AUSTRIA
Linz Drive Centre
T: +43 7229 789480
controltechniques.at@emerson.com

BELGIUM
Brussels Drive Centre
T: +32 1574 0700
controltechniques.be@emerson.com

BRAZIL
Emerson do Brazil Ltda
T: +5511 3618 6569
controltechniques.br@emerson.com

CANADA
Toronto Drive Centre
T: +1 905 201 4699
controltechniques.ca@emerson.com

Calgary Drive Centre
T: +1 403 253 8738
controltechniques.ca@emerson.com

CHINA
Shanghai Drive Centre
T: +86 21 5426 0668
controltechniques.ch@emerson.com

Beijing Application Centre
T: +86 10 856 31122 ext 820
controltechniques.ch@emerson.com

CZECH REPUBLIC
Brno Drive Centre
T: +420 541 192111
controltechniques.cz@emerson.com

DENMARK
Copenhagen Drive Centre
T: +45 4369 6100
controltechniques.dk@emerson.com

FRANCE*
Angoulême Drive Centre
T: +33 5 4564 5454
controltechniques.fr@emerson.com

GERMANY
Bonn Drive Centre
T: +49 2242 8770
controltechniques.de@emerson.com

Chemnitz Drive Centre
T: +49 3722 52030
controltechniques.de@emerson.com

Darmstadt Drive Centre
T: +49 6251 17700
controltechniques.de@emerson.com

GREECE*
Athens Application Centre
T: +0030 210 57 86086/088
controltechniques.gr@emerson.com

HOLLAND
Rotterdam Drive Centre
T: +31 184 420555
controltechniques.nl@emerson.com

HONG KONG
Hong Kong Application Centre
T: +852 2979 5271
controltechniques.hk@emerson.com

INDIA
Chennai Drive Centre
T: +91 44 2496 1123/
2496 1130/2496 1083
controltechniques.in@emerson.com

Pune Application Centre
T: +91 20 2612 7956/2612 8415
controltechniques.in@emerson.com

New Delhi Application Centre
T: +91 11 2 576 4782/2 581 3166
controltechniques.in@emerson.com

IRELAND
Newbridge Drive Centre
T: +353 45 448200
controltechniques.ie@emerson.com

ITALY
Milan Drive Centre
T: +39 02575 751
controltechniques.it@emerson.com

Reggio Emilia Application Centre
T: +39 02575 751
controltechniques.it@emerson.com

Vicenza Drive Centre
T: +39 0444 933400
controltechniques.it@emerson.com

KOREA
Seoul Application Centre
T: +82 2 3483 1605
controltechniques.kr@emerson.com

MALAYSIA
Kuala Lumpur Drive Centre
T: +603 5634 9776
controltechniques.my@emerson.com

REPUBLIC OF SOUTH AFRICA
Johannesburg Drive Centre
T: +27 11 462 1740
controltechniques.za@emerson.com

Cape Town Application Centre
T: +27 21 556 0245
controltechniques.za@emerson.com

RUSSIA
Moscow Application Centre
T: +7 495 981 9811
controltechniques.ru@emerson.com

SINGAPORE
Singapore Drive Centre
T: +65 6468 8979
controltechniques.sg@emerson.com

SLOVAKIA
EMERSON A.S.
T: +421 32 7700 369
controltechniques.sk@emerson.com

SPAIN
Barcelona Drive Centre
T: +34 93 680 1661
controltechniques.es@emerson.com

Bilbao Application Centre
T: +34 94 620 3646
controltechniques.es@emerson.com

Valencia Drive Centre
T: +34 96 154 2900
controltechniques.es@emerson.com

SWEDEN*
Stockholm Application Centre
T: +468 554 241 00
controltechniques.se@emerson.com

SWITZERLAND
Lausanne Application Centre
T: +41 21 637 7070
controltechniques.ch@emerson.com

Zurich Drive Centre
T: +41 56 201 4242
controltechniques.ch@emerson.com

TAIWAN
Taipei Application Centre
T: +886 22325 9555
controltechniques.tw@emerson.com

THAILAND
Bangkok Drive Centre
T: +66 2962 2092 99
controltechniques.th@emerson.com

TURKEY
Istanbul Drive Centre
T: +90 216 4182420
controltechniques.tr@emerson.com

UAE*
Emerson FZE
T: +971 4 8118100
ct.dubai@emerson.com

UNITED KINGDOM
Telford Drive Centre
T: +44 1952 213700
controltechniques.uk@emerson.com

USA
California Drive Centre
T: +1 562 943 0300
controltechniques.us@emerson.com

Charlotte Application Centre
T: +1 704 393 3366
controltechniques.us@emerson.com

Chicago Application Centre
T: +1 630 752 9090
controltechniques.us@emerson.com

Cleveland Drive Centre
T: +1 440 717 0123
controltechniques.us@emerson.com

Florida Drive Centre
T: +1 239 693 7200
controltechniques.us@emerson.com

Latin America Sales Office
T: +1 305 818 8897
controltechniques.us@emerson.com

Minneapolis US Headquarters
T: +1 952 995 8000
controltechniques.us@emerson.com

Oregon Drive Centre
T: +1 503 266 2094
controltechniques.us@emerson.com

Providence Drive Centre
T: +1 401 541 7277
controltechniques.us@emerson.com

Utah Drive Centre
T: +1 801 566 5521
controltechniques.us@emerson.com

Control Techniques Distributors

ARGENTINA
Euro Techniques SA
T: +54 11 4331 7820
eurotech@eurotechsa.com.ar

BAHRAIN
Emerson FZE
T: +971 4 8118100
ct.bahrain@emerson.com

BULGARIA
BLS - Automation Ltd
T: +359 32 968 007
info@blsautomation.com

CENTRAL AMERICA
Mercado Industrial Inc.
T: +1 305 854 9515
rsaybe@mercadoindustrialinc.com

CHILE
Ingeniería Y Desarrollo
Tecnológico S.A
T: +56 2741 9624
idt@idt.cl

COLOMBIA
Sistronic LTDA
T: +57 2 555 60 00
sistronic@telesat.com.co

CROATIA
Zigg-Pro d.o.o
T: +385 1 3463 000
zigg-pro@zg.htnet.hr

CYPRUS
Acme Industrial Electronic
Services Ltd
T: +3572 5 332181
acme@cytanet.com.cy

EGYPT
Samiram
T: +202 7360849/+202 7603877
samiramz@samiram.com

FINLAND
SKS Control
T: +358 207 6461
control@sks.fi

HUNGARY
Control-VH Kft
T: +361 431 1160
info@controlvh.hu

ICELAND
Samey ehf
T: +354 510 5200
samey@samey.is

INDONESIA
Pt Apikon Indonesia
T: +65 6468 8979
info.my@controltechniques.com

Pt Yua Esa Sempurna Sejahtera
T: +65 6468 8979
info.my@controltechniques.com

ISRAEL
Dor Drives Systems Ltd
T: +972 3900 7595
info@dor1.co.il

KENYA
Kassam & Bros Co. Ltd
T: +254 2 556 418
kassambros@africaonline.co.ke

KUWAIT
Emerson FZE
T: +971 4 8118100
ct.kuwait@emerson.com

LATVIA
EMT
T: +371 760 2026
janis@emt.lv

LEBANON
Black Box Automation & Control
T: +961 1 443773
info@blackboxcontrol.com

LITHUANIA
Eliinta UAB
T: +370 37 351 987
sigitas@eliinta.lt

MALTA
Mekanika Limited
T: +35621 442 039
mfranca@gasan.com

MEXICO
MELCSA
T: +52 55 5561 1312
melcsamx@iserve.net.mx
SERVITECK, S.A de C.V
T: +52 55 5398 9591
servitek@data.net.mx

MOROCCO
Leroy Somer Maroc
T: +212 22 354948
lsmaroc@wanadoopro.ma

NEW ZEALAND
Advanced Motor Control. Ph.
T: +64 (0) 274 363 067
info.au@controltechniques.com

PHILIPPINES
Control Techniques
Singapore Ltd
T: +65 6468 8979
info.my@controltechniques.com

POLAND
APATOR CONTROL Sp. z o.o
T: +48 56 6191 207
drives@apator.torun.pl

PORTUGAL
Harker Summer S.A
T: +351 22 947 8090
drives.automation@harker.pt

PUERTO RICO
Powermotion
T: +1 787 843 3648
dennis@powermotionpr.com

QATAR
Emerson FZE
T: +971 4 8118100
ct.qatar@emerson.com

SAUDI ARABIA
A. Abunayyan Electric Corp.
T: +9661 477 9111
aec-salesmarketing@
abunayyagroup.com

SERBIA & MONTENEGRO
Master Inzenjering d.o.o
T: +381 24 551 605
master@eunet.yu

SLOVENIA
PS Logatec
T: +386 1 750 8510
ps-log@ps-log.si

TUNISIA
SIA Ben Djemaa & CIE
T: +216 1 332 923
bendjemaa@planet.tn

URUGUAY
SECOIN S.A.
T: +5982 2093815
secoin@secoin.com.uy

VENEZUELA
Digimex Sistemas C.A.
T: +58 243 551 1634

VIETNAM
N.Duc Thinh
T: +84 8 9490633
infotech@nducthinh.com.vn