



**EMERSON**<sup>™</sup>  
Industrial Automation

## Digitax *ST*

Servo drives range  
Intelligent, Compact and Dynamic

From 0.72Nm to 19.3Nm (57.7Nm Peak)



**CONTROL  
TECHNIQUES**

[www.controltechniques.com](http://www.controltechniques.com)

## THE ULTIMATE SERVO DRIVE

Meeting the demands of modern lean manufacturing environments requires smaller more flexible machinery. Digitax ST is the first ever drive designed to help machine designers and system integrators meet these challenges, the ultimate compact servo drive with an unmatched depth of flexible integration features.

### Designed around you

Digitax ST is optimised for servo applications requiring high peak torque, dynamic response, ease of use and flexible integration features. Four product variants ensure that the drive's personality perfectly matches your servo applications.

- **Digitax ST – Base**

Optimised for centralised control, to operate with motion controllers, motion PLCs and Industrial PC based motion systems using a wide range of digital or analogue interface technologies.

- **Digitax ST – Indexer**

Designed for simple stand alone positioning applications using an onboard position controller. Fieldbus, Ethernet and I/O enable connectivity to other automation components.

- **Digitax ST – EZ Motion**

This drive offers a stand alone solution for many common indexing and synchronised motion applications. This is achieved using a unique, PC programming interface that guides the user through the drive, I/O and motion configuration.

- **Digitax ST – Plus**

Features a full functionality motion controller, optimised for high performance machine cells requiring drive-to-drive networking and precision synchronisation. The motion and communications are configured within a flexible IEC61131-3 software development environment using PLCOpen function blocks. Fieldbus, Ethernet and I/O connectivity enable interfacing with other automation components and Intellectual Property protection ensures that your valuable knowledge remains secure.



### Reliability and Innovation

Digitax ST is designed using a well proven development process that prioritises innovation and reliability. This process has resulted in Control Techniques having a market leading reputation for both product performance and quality.

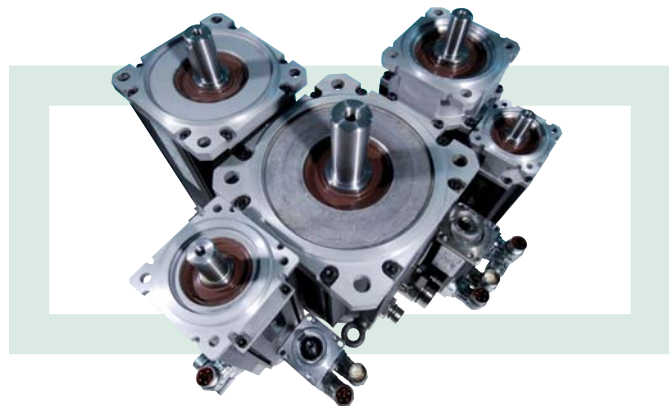

### Global Service

Control Techniques' 54 Drive Centres located in 31 countries ensure that service, support and expertise are just around the corner, all around the world.



**RoHS  
Compliant**



LISTED E171230

AC Input Power,  
48Vdc & Dynamic  
Brake Terminals

Cable  
Management

Optional  
Removable  
Keypad

Programming  
Port

Analogue I/O

Digital I/O  
& 24Vdc

Safe  
Torque  
Off

Relay  
Output

Cable  
Management

Quick and easy mounting  
arrangement with DIN rail clip

Motor Output  
& DC Bus

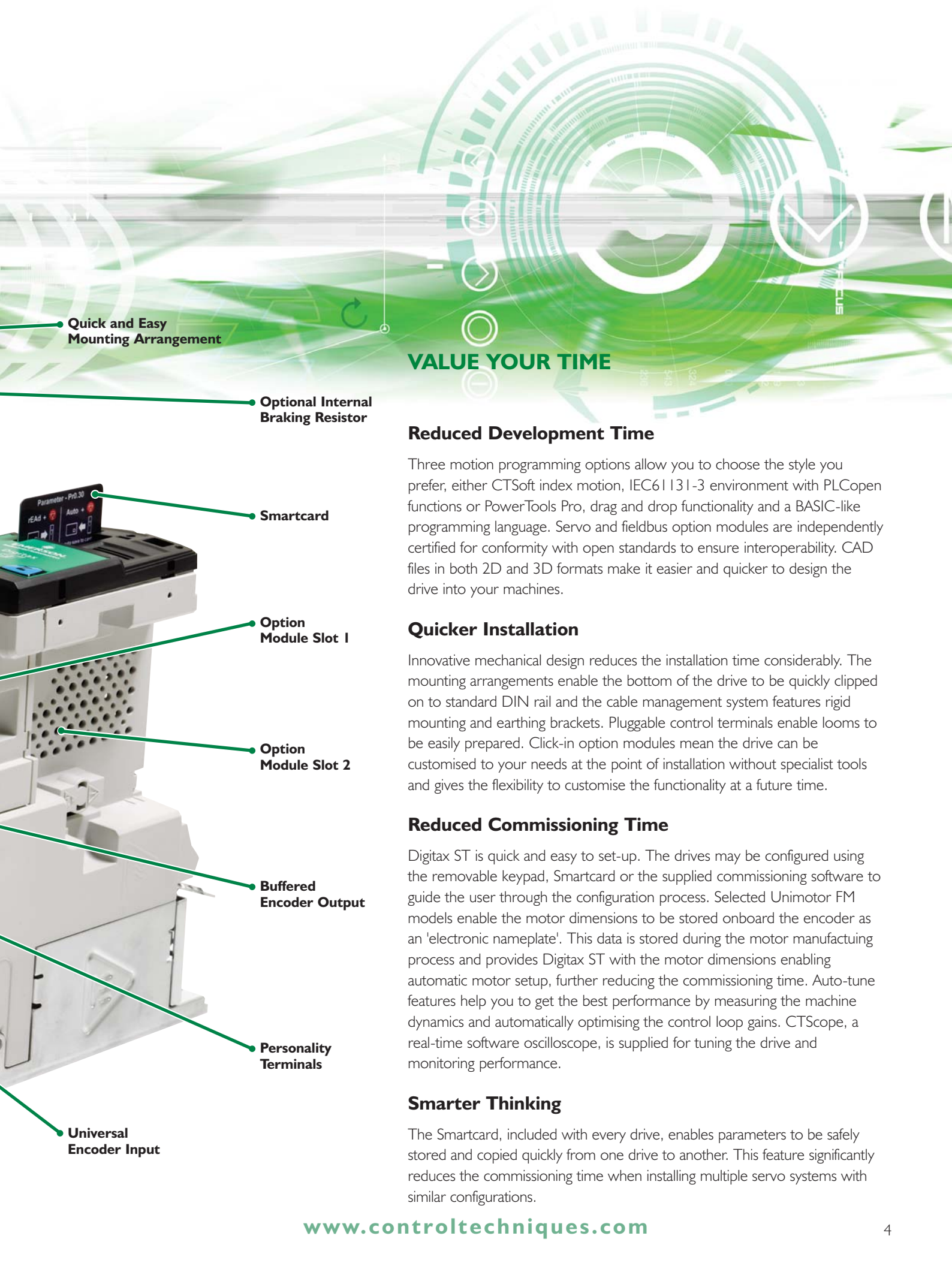

**Quick and Easy Mounting Arrangement**

**Optional Internal Braking Resistor**

**Smartcard**

**Option Module Slot 1**

**Option Module Slot 2**

**Buffered Encoder Output**

**Personality Terminals**

**Universal Encoder Input**

## VALUE YOUR TIME

### Reduced Development Time

Three motion programming options allow you to choose the style you prefer, either CTSsoft index motion, IEC61131-3 environment with PLCopen functions or PowerTools Pro, drag and drop functionality and a BASIC-like programming language. Servo and fieldbus option modules are independently certified for conformity with open standards to ensure interoperability. CAD files in both 2D and 3D formats make it easier and quicker to design the drive into your machines.

### Quicker Installation

Innovative mechanical design reduces the installation time considerably. The mounting arrangements enable the bottom of the drive to be quickly clipped on to standard DIN rail and the cable management system features rigid mounting and earthing brackets. Pluggable control terminals enable looms to be easily prepared. Click-in option modules mean the drive can be customised to your needs at the point of installation without specialist tools and gives the flexibility to customise the functionality at a future time.

### Reduced Commissioning Time

Digitax ST is quick and easy to set-up. The drives may be configured using the removable keypad, Smartcard or the supplied commissioning software to guide the user through the configuration process. Selected Unimotor FM models enable the motor dimensions to be stored onboard the encoder as an 'electronic nameplate'. This data is stored during the motor manufacturing process and provides Digitax ST with the motor dimensions enabling automatic motor setup, further reducing the commissioning time. Auto-tune features help you to get the best performance by measuring the machine dynamics and automatically optimising the control loop gains. CTSscope, a real-time software oscilloscope, is supplied for tuning the drive and monitoring performance.

### Smarter Thinking

The Smartcard, included with every drive, enables parameters to be safely stored and copied quickly from one drive to another. This feature significantly reduces the commissioning time when installing multiple servo systems with similar configurations.

## COMPACT & COMPLETE

### More Compact Machinery

Digitax ST is an extremely compact servo drive that can be mounted side-by-side with other drives or components without leaving space. The result is an incredibly high packing density for multiple axes. Onboard features such as synchronised motion control and Safe Torque Off reduce the need for external components further reducing cubicle sizes and cost.

### Matched Motors

Unimotor FM is a performance matched range of servo motors. FM means Flexible Motor, available in six different diameters with a wide range of motor lengths, rated speeds and feedback devices.

Factory fitted options include integral brakes and servo gear boxes.

Digitax ST operates successfully with other manufacturers' servo motors including linear motors and almost any feedback device.



### Increased Value

How do you increase the value of your machines while reducing your costs? Digitax ST offers reliability, and the performance to increase speed, repeatability and accuracy while also reducing the size and cost. Digitax ST addresses all of the challenges associated with modern machine design.

	Digitax ST - Base	Digitax ST - Indexer	Digitax ST - EZ Motion	Digitax ST - Plus
Two option module slots	✓	✓	✓	✓
Digital and analogue I/O with pluggable connector	✓	✓	✓	✓
Smartcard	✓	✓	✓	✓
High speed Freeze input for position capture	✓	✓	✓	✓
Safe Torque Off (Secure Disable)	✓	✓	✓	✓
CTSoft and CTScope commissioning software	✓	✓		✓
Removable keypad (optional)	✓	✓	✓	✓
RS485 PC programming port	✓	✓	✓	✓
Intellectual Property Protection		✓		✓
Index motion programming within CTSoft		✓		Able to import Index Motion
Program multi-tasking			✓	✓
PowerTools Pro programming environment			✓	
SyPT Pro programming environment with PLCopen programming				✓
Drive-to-drive networking				✓



### Typical Applications

- Packaging
- Pick and place
- Glue depositing
- Metal, glass, plastic and fabric x y cutting tables
- Materials Handling
- Profiling applications

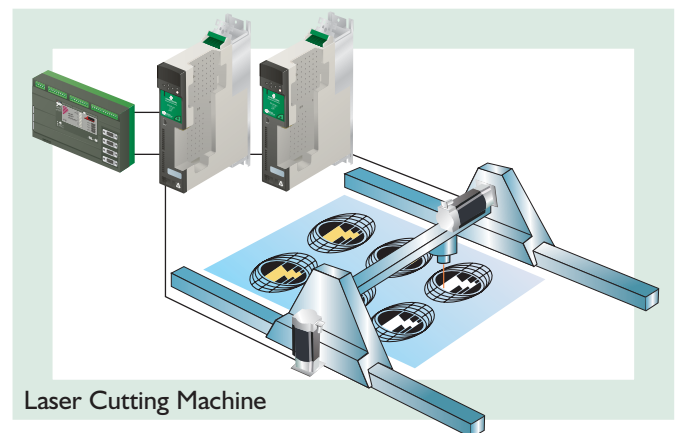
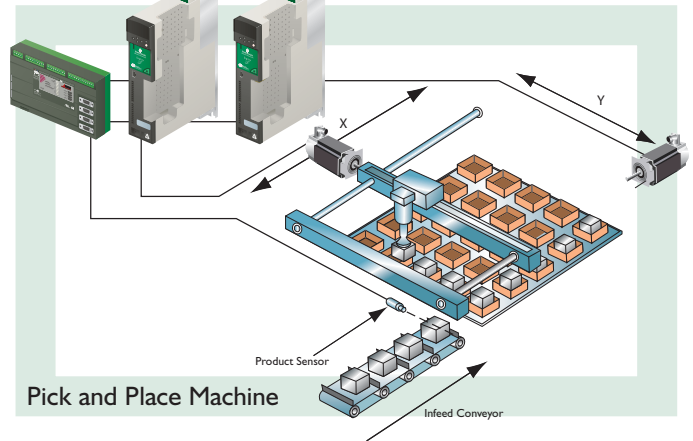

## DIGITAX ST - BASE

### Centralised, coordinated motion

Digitax ST - Base is designed for integration with centralised motion controllers, connected using either digital communications or analogue technologies. The drive offers optimised servo performance, flexible connectivity and is quick and simple to configure using either the optional keypad, Smartcard or CTSoft, an intuitive drive configuration software that is included with every drive.



## Typical Architecture

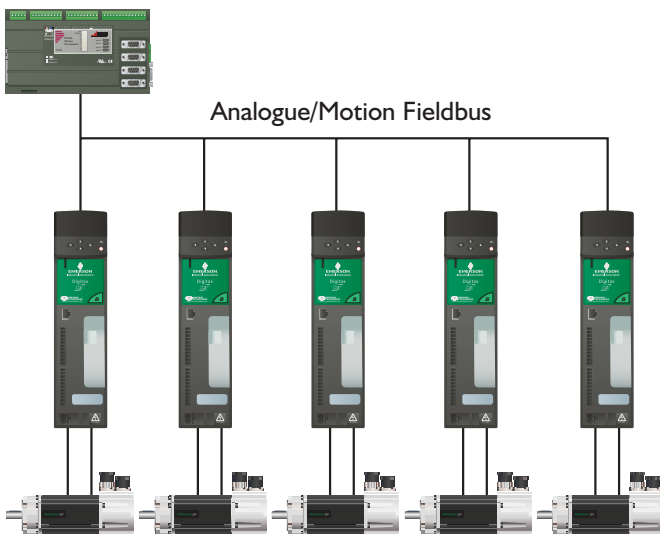

## Key Benefits

Option modules with synchronous drive connectivity allow the drive to interface using dedicated servo networks such as EtherCAT, SERCOS and CANopen. Compliance certification ensures interoperability with other manufacturers' equipment.

The standard I/O includes high speed Freeze input for position capture, high resolution analogue input and an encoder output to enable the drive to be connected to traditional motion controllers.

The on-board universal encoder input is able to connect to Incremental, SinCos, Hiperface, EnDAT and SSI encoders allowing you to choose the best feedback device for each application.

As standard the drive features a Safe Torque Off input, which disables the output stage of the drive with a high degree of security. This reduces the cost of complying with machine safety standards such as EN954-1 Cat 3 and enables the drive to integrate easily with the machine safety system.

## Key Option Modules

### Communications

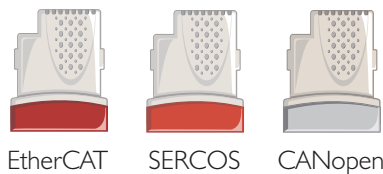

### Feedback

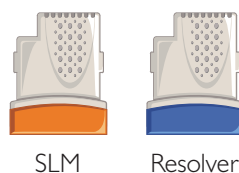



### Typical Applications

- Indexing tables
- Fast conveyor positioning
- Cut-to-length machines
- Punching
- Transfer mechanisms
- Fast and precise fluid dispensing

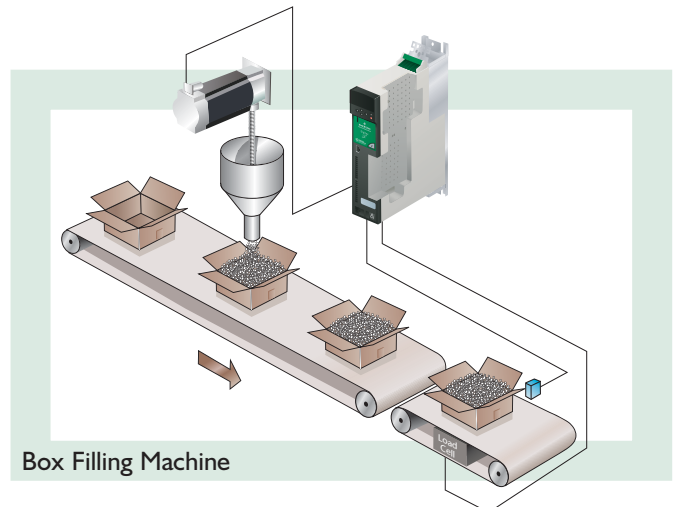
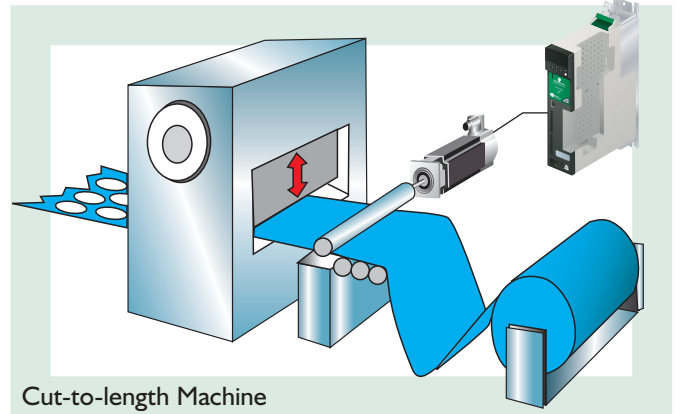

## DIGITAX ST – INDEXER

### Easy to use, point-to-point positioning

Digitax ST - Indexer has the same high performance features as the Base model, but additionally offers easy to use point-to-point positioning functionality. The drive can operate as a standalone controller or integrate with a wider automation system using fieldbus and I/O. The drive and positioning features are commissioned using CTSOft, an intuitive drive configuration software that is included free with every drive.

## Typical Architecture

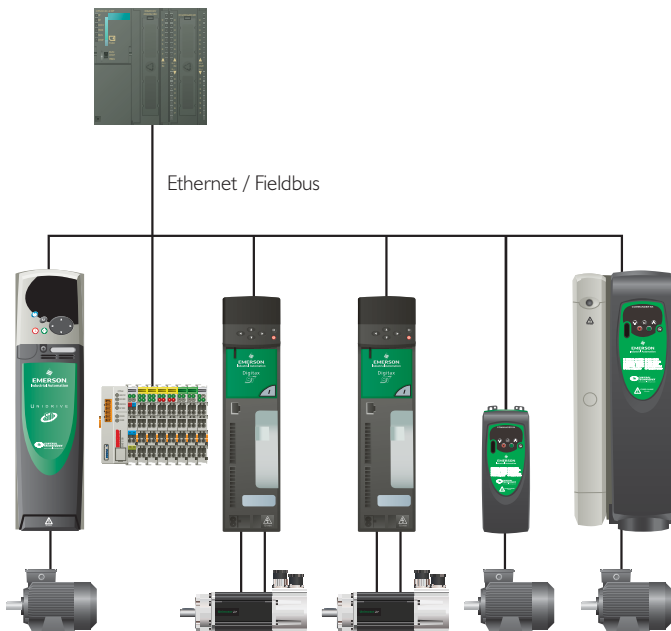

## Key Option Modules

### Communications

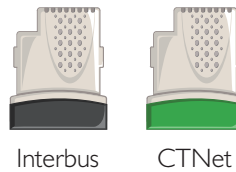
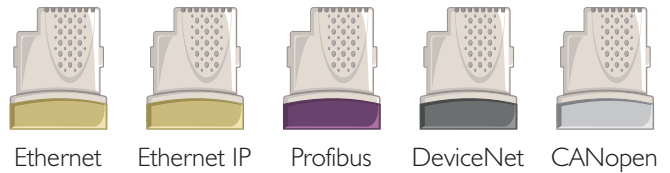

### Feedback

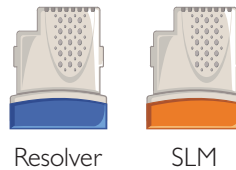

### Input and Output

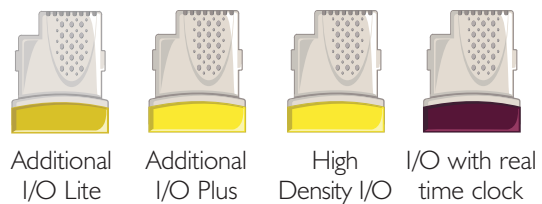

## Key Benefits

On-board motion controller with easy-to-use yet powerful graphical software tools enable positioning applications to be configured quickly and easily using the graphical sequential function chart language.

Option modules for Ethernet and fieldbus connectivity such as Profibus and DeviceNet allow the drive to integrate with a wider automation system.

Positioning applications developed for the Indexer can be imported into SyPT Pro, giving access to more advanced features and drive-to-drive communications.



## Typical Applications

- Indexing table
- Pick and place
- Packaging machines
- Dancer arm loop control
- High speed labelling
- Rotary knife

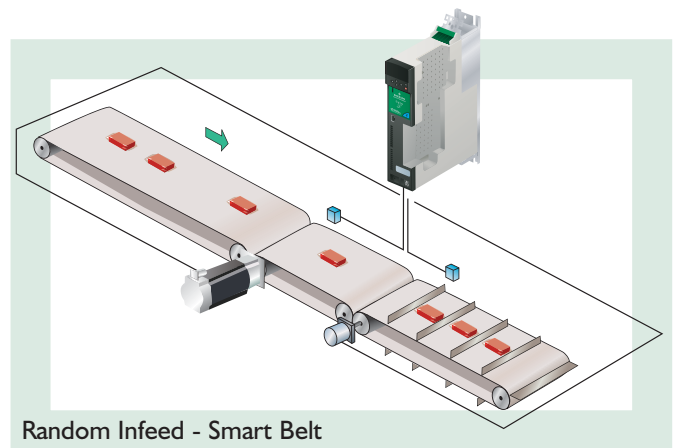

Random Infeed - Smart Belt

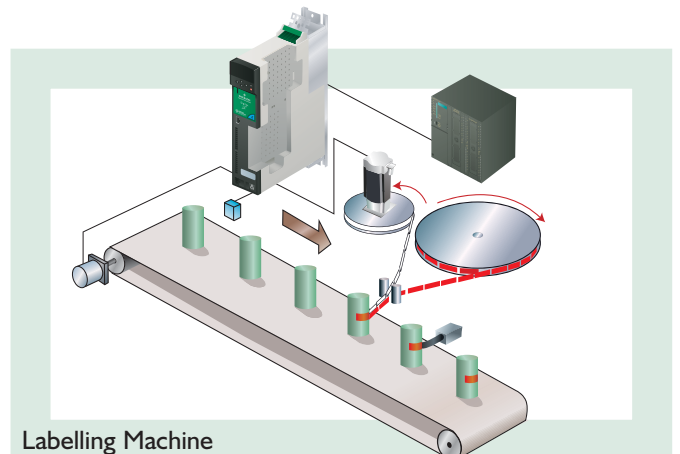

Labelling Machine

## DIGITAX ST – EZ MOTION

### Easy motion for indexing and synchronised motion applications

Digitax ST – EZ Motion features an easy to use programming environment making motion control accessible to experienced and first time motion users alike. While simplicity is a primary focus, performance is not compromised, offering a precision servo solution for many common indexing and synchronised motion applications.



## Typical Architecture

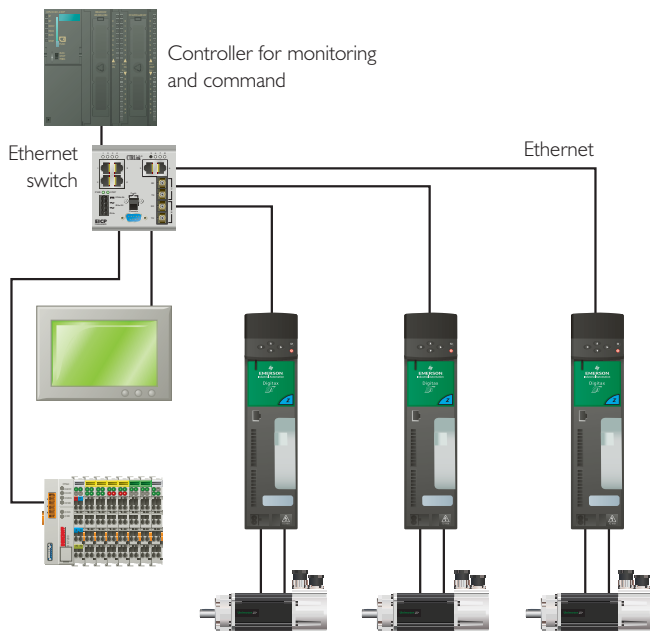

## Key Option Modules

### Communications

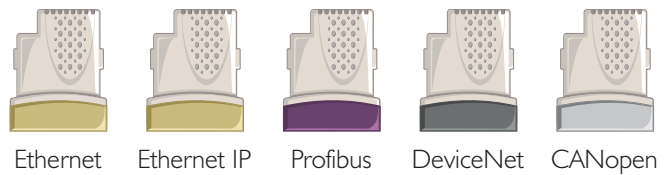

### Feedback

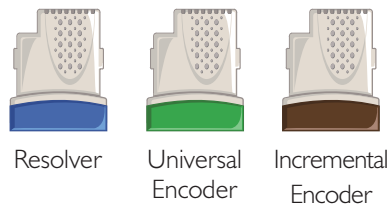

## Key Benefits

Digitax ST - EZ Motion is supplied with PowerTools Pro, an easy-to-use software tool for configuration, commissioning and monitoring of all aspects of the drive and motion application.

High level software features help you to reduce your development time. Motion configurations such as travel limits, queuing and gearing are easily deployed within PowerTools Pro software using easy to complete forms and drag and drop functionality.

Six additional high-speed digital I/O points can be used for position capture and system interfacing enabling more complex applications and registration features to be implemented.

### Input and Output

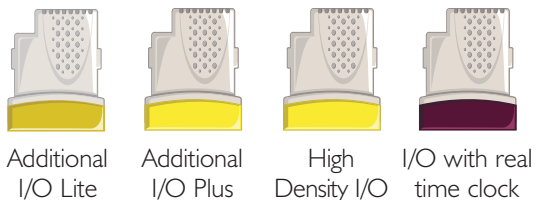



### Typical Applications

- Printing
- Packaging
- Synchronising conveyors
- Flying shear
- Rotary knife
- Winder traverse for textile/cable

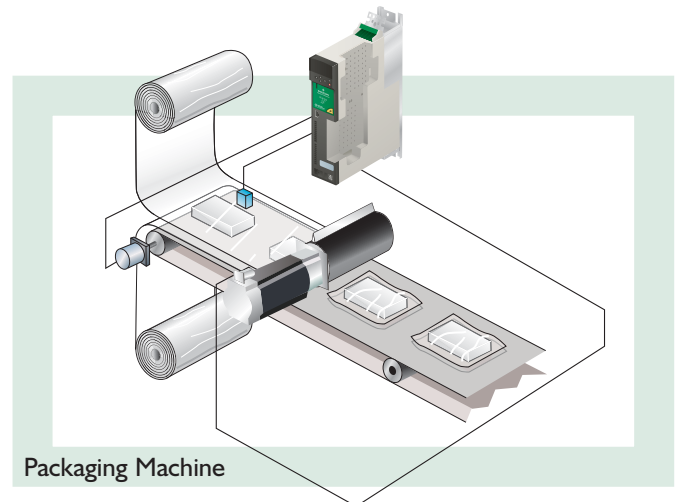
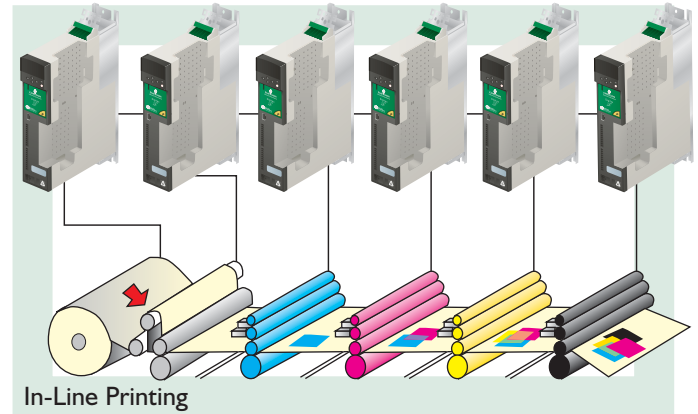

## DIGITAX ST - PLUS

### Flexibility for the most demanding motion applications

Digitax ST - Plus offers all of the features available on the indexer drive together with more advanced motion functionality including cam profiling and synchronised motion. Onboard drive-to-drive networking links multiple axes and enables true distributed control. The drive is commissioned using CTSOft, an intuitive drive configuration software that is included free with every drive. The advanced motion features are configured using PLCOpen motion function blocks within Control Techniques SyPT Pro automation development environment.



## Typical Architecture

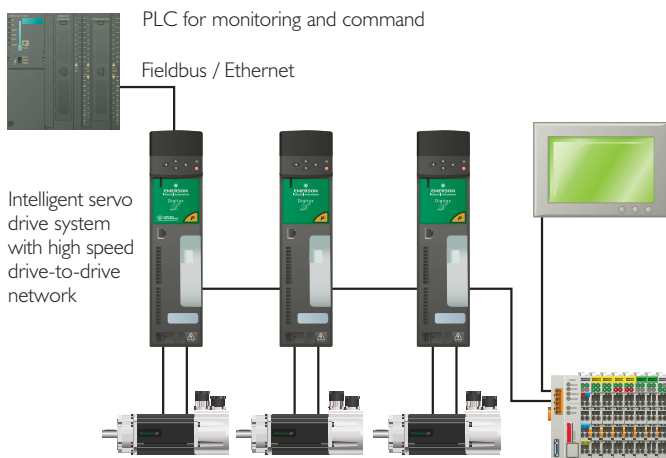

## Key Benefits

On-board position controller ensures superior performance and reduced cubicle space.

Digitax ST - Plus is configured using Control Techniques market leading development environment, SyPT Pro. Standard IEC61131-3 languages, multi-tasking and PLCopen motion function blocks increase familiarity and reduce the development time.

Digitax ST - Plus prevents others benefiting from your unique knowledge. SyPT Pro can protect your Intellectual Property by downloading only the compiled binary version of your software (not the source code) therefore preventing your customers and competitors from accessing your work.

Many machinery users have different site standards for PLCs. This presents you with the challenge of designing standard machine sections that are independent of your customers PLC preference. With on-board intelligence, drive-to-drive synchronisation and a wide range of network communication options, Digitax ST makes it easy for you to standardise your designs whilst retaining full connectivity to any PLC.

High speed, deterministic drive-to-drive communications reduces wiring and improves the system performance.

Control Techniques drive-to-drive network allows Digitax ST - Plus to integrate closely with other automation devices such as HMIs, PCs, I/O and other Control Techniques drives such as Unidrive SP and Mentor.

## Key Option Modules

### Communications

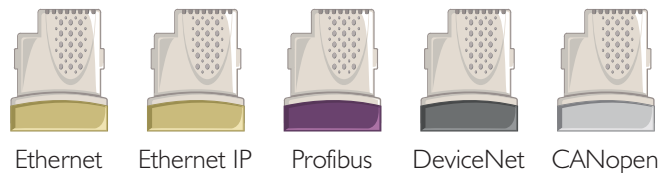

### Feedback

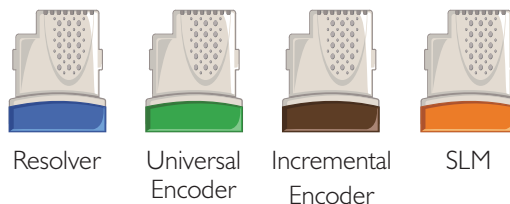

### Input and Output

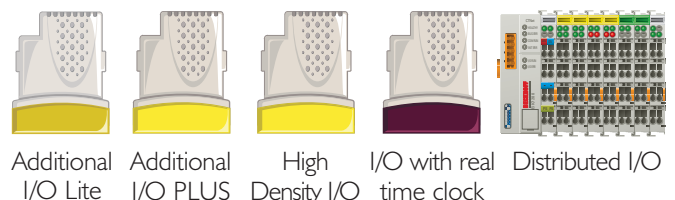

## CONTROL TECHNIQUES SOFTWARE

Control Techniques makes it easier to access the drive's full feature set. Our software allows you to optimise the drive tuning, back-up the configuration, configure the on-board motion controller and design the drive-to-drive network data links. There are five main software packages:

- CTSoft - Drive configuration and index motion editor
- CTScope - Real-time software oscilloscope
- PowerTools Pro - Easy to use, all in one drive configuration software for Digitax ST - EZ Motion drives
- SyPT Pro - Drive automation and motion programming environment
- CTOPCServer - OPC compliant server for interfacing your own PC software with Control Techniques drives

The software packages connect using Ethernet, CTNet, Serial or USB connections. Ethernet communications allow the drives to be accessed remotely, anywhere in the world.

	Ethernet	RS485	CTNet	USB
CT Soft	✓	✓	✓	✓
CTScope	✓	✓	✓	✓
PowerTools Pro	✓	✓		✓
SyPT Pro	✓	✓	✓	✓
CTOPCServer	✓	✓	✓	✓





### CTSoft

	Base	Indexer	EZ Motion	Plus
Available for	✓	✓		✓

CTSoft is a drive configuration tool for commissioning, optimising and monitoring Control Techniques drives. It allows you to:

- Use the configuration wizards to commission your drive
- Program the Digitax ST on-board motion controller
- Read, save and load drive configuration settings
- Manage the drive's smartcard data
- Visualise and modify the configuration with live animated diagrams

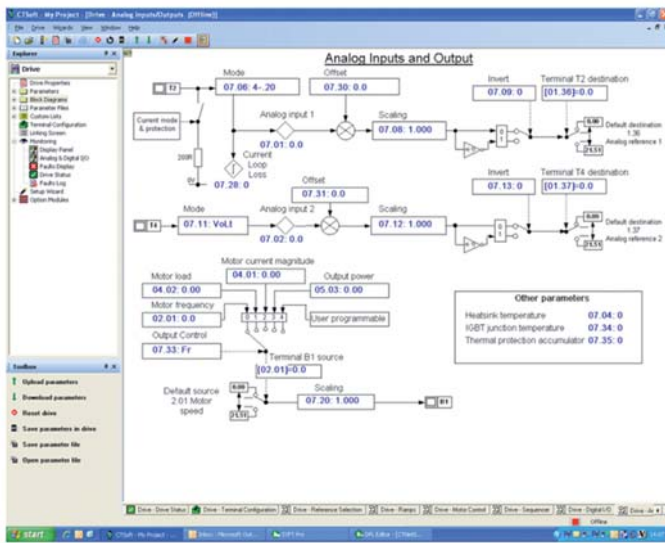

For evaluation, download the full software from [www.controltechniques.com](http://www.controltechniques.com)



### Index Motion Controller

	Base	Indexer	EZ Motion	Plus
Available for		✓		

Digitax ST - index motion controller is programmed within CTSoft using industry standard Sequential Function Chart (SFC) language. The user can quickly configure a range of motion commands such as homing and various index moves. The focus is on reducing development time and ease of use.

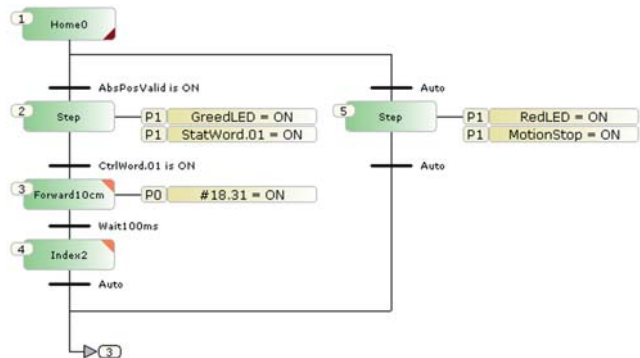

The status of the program can be monitored, and the speed of the motion reduced for commissioning and testing purposes:

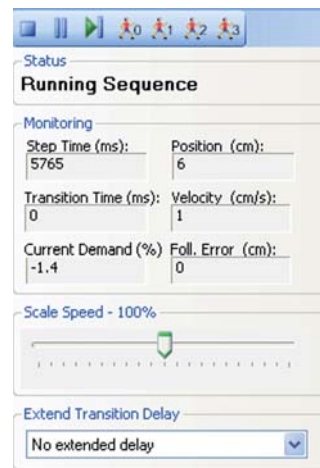

For evaluation, download the full software from [www.controltechniques.com](http://www.controltechniques.com)



### CTScope

	Base	Indexer	EZ Motion	Plus
Available for	✓	✓		✓

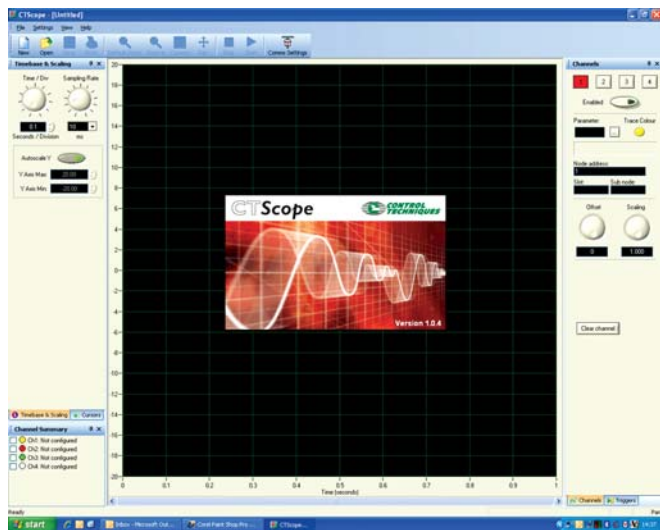

CTScope is a full featured software oscilloscope for viewing and analysing changing values within the drive. The time base can be set to give high speed capture for tuning or intermittent capture for longer term trends. The user interface is based on a traditional oscilloscope, making it familiar and friendly to all engineers across the globe.

For evaluation, download the full software from [www.controltechniques.com](http://www.controltechniques.com)



### PowerTools Pro

	Base	Indexer	EZ Motion	Plus
Available for			✓	

Developing motion applications with PowerTools Pro is a simple “five step, top-down process”. The five steps are displayed within an explorer bar that allows easy intuitive navigation. Each step is configured using simple check boxes, drop down selections and drag and drop functionality. The five steps are:

- Hardware Configuration
- Drive Setup
- I/O Setup
- Motion
- Programs

A “BASIC”-like programming language enables users to develop more complex applications and sequencing with functions being selected by dragging and dropping onto the work area.

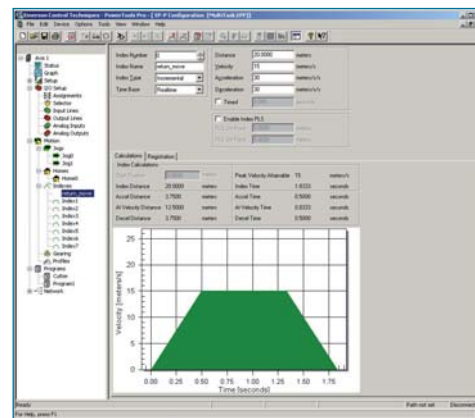

For evaluation, download the full software from [www.controltechniques.com](http://www.controltechniques.com)





	Base	Indexer	EZ Motion	Plus
Available for				✓

SyPT Pro is a full featured automation development environment that can be used for developing solutions for single or multiple axis applications. The programming environment supports three industry standard languages: Function Block, Ladder and Structured Text. Motion control is configured using the new PLCopen motion language, supporting up to 1.5 axes. CTNet, a high-speed, drive-to-drive network links the drives, SCADA and I/O together to form an intelligent networked system. SyPT Pro manages both the system programming and motion communications.

For evaluation, download a demo version of the software at [www.syptpro.com](http://www.syptpro.com).

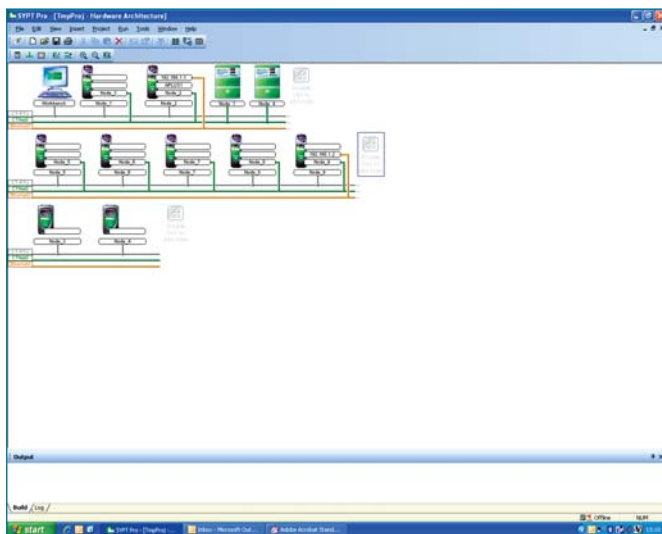

For more information please refer to SyPT Pro brochure, part number 0175-0334



### CTOPCserver

	Base	Indexer	EZ Motion	Plus
Available for	✓	✓	✓	✓

CTOPCServer is an OPC compliant server which allows PCs to communicate with Control Techniques drives. The server supports communication using Ethernet, CTNet, RS485 and USB. OPC is a standard interface on SCADA packages and is widely supported within Microsoft™ products. The server is supplied free of charge and may be downloaded from [www.controltechniques.com](http://www.controltechniques.com).



## UNIMOTOR FM 0.72Nm - 19.3Nm

Performance AC Brushless Servo Motor

### Overview

Unimotor FM a high performance brushless AC servo motor range matched for use with Control Techniques drives. FM means Flexible Motor, designed to accommodate a wide range of applications. The motors are available in six frame sizes with various mounting arrangements and motor lengths.

### Benefits

- Unimotor FM allows various feedback devices to be used. The standard feedback device is an incremental encoder as this offers an optimum balance of cost and performance. SinCos and SLM feedback can be selected for increased resolution and Resolver feedback is available for use in extreme environments
- High peak torque values allow smaller motors to be used where the RMS value is low but the maximum torque is high
- A wide selection of ready made cables is available for quick and easy connection to Control Techniques drives
- High inertia versions are available to allow the motor inertia to be more closely matched to the load inertia for increased performance and stability
- IP65 environmental protection is standard and ATEX protection is available as an option
- Motor brakes may be integrated within the motor, a choice of parking brake or high energy dissipation brake is available
- Other options include plain or keyed shaft and various flange shaft combinations.
- Flexibility of the Unimotor range ensures the best fit for your application, as well as the various physical sizes and feedback devices available, options extend to the type of connectors fitted

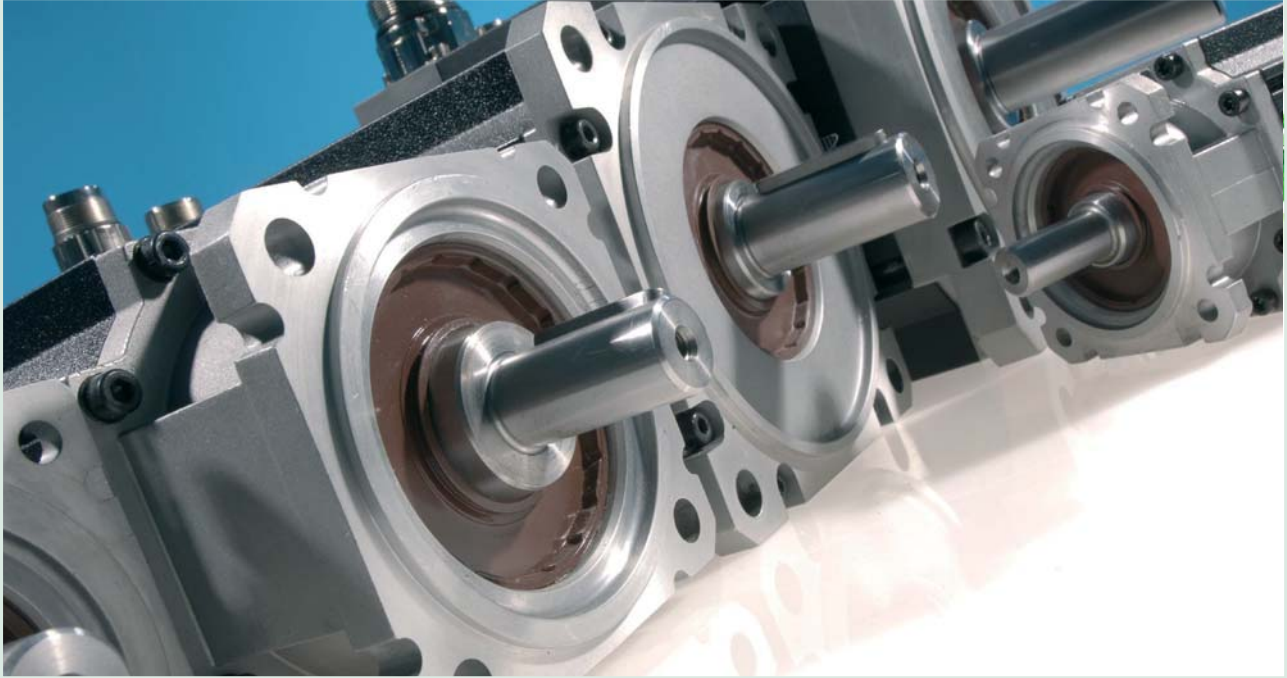

## AVAILABLE MOTOR / DRIVE COMBINATIONS

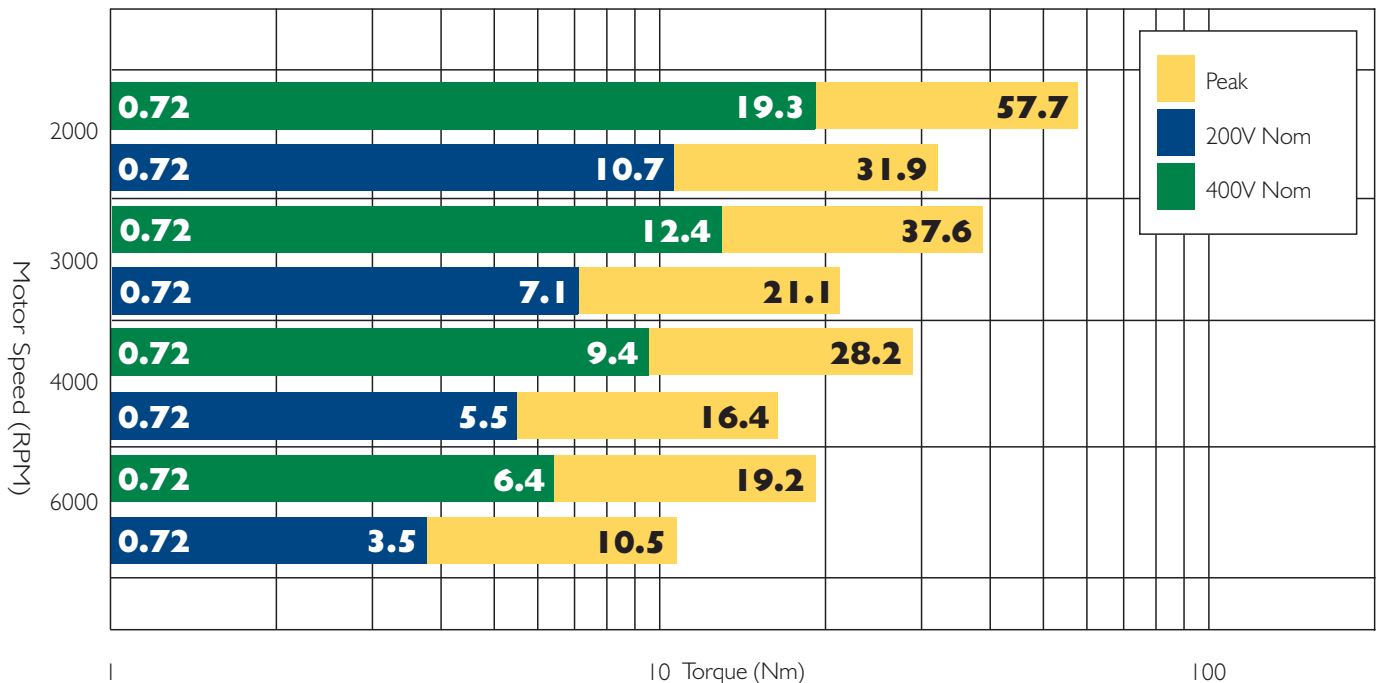

NB: The selection of Drive-Motor combinations should be based on Duty/Load Profiles of the application

## DIGITAX ST UNIMOTOR FM @ 2000RPM COMBINATIONS

Table data based on 2000 rpm motors 3x Stall Torque

200V						
Drive Part No.	Stall Nm	Stall Amp	Peak Nm	Peak Amp	Inertia kg/cm <sup>2</sup>	Motor Part No.
DST1201	0.72	1.0	2.16	2.9	0.12	055E2A300
DST1201	1.2	0.9	3.6	2.6	0.7	075E2A200
DST1201	1.4	1.7	4.2	5.1	0.23	055E2B300
DST1202	2.1	2.4	6.3	7.3	0.34	055E2C300
DST1201	2.2	1.6	6.6	4.7	1.2	075E2B200
DST1201	2.3	1.6	6.9	4.9	1.7	095E2A200
DST1202	3.1	2.2	9.3	6.6	1.6	075E2C200
DST1202	3.5	2.5	10.5	7.5	4.4	115E2A200
DST1202	3.9	2.8	11.7	8.4	2	075E2D200
DST1202	4.3	3.1	12.9	9.2	2.9	095E2B200
DST1203	5.7	4.1	17.1	12.2	9	142E2A200
DST1203	5.9	4.2	17.7	12.6	4	095E2C200
DST1203	6.6	4.7	19.8	14.1	6.7	115E2B200
DST1203	7.5	5.4	22.5	16.1	5.1	095E2D200
DST1204	9.0	6.4	27	19.3	6.2	095E2E200
DST1204	9.4	6.7	28.2	20.1	9	115E2C200
DST1204	9.6	6.9	28.8	20.6	29.9	190E2A200
DST1204	10.7	7.6	31.9	22.8	15.6	142E2B200*

\* Motor output limited by drive rating

400V						
Drive Part No.	Stall Nm	Stall Amp	Peak Nm	Peak Amp	Inertia kg/cm <sup>2</sup>	Motor Part No.
DST1401	0.72	0.9	2.16	2.8	0.12	055U2A300
DST1401	1.2	0.5	3.6	1.5	0.7	075U2A200
DST1401	1.4	0.9	4.2	2.8	0.23	055U2B300
DST1401	2.1	1.3	6.3	4.0	0.34	055U2C300
DST1401	2.2	0.9	6.6	2.8	1.2	075U2B200
DST1401	2.3	1.0	6.9	2.9	1.7	095U2A200
DST1401	3.1	1.3	9.3	3.9	1.6	075U2C200
DST1401	3.5	1.5	10.5	4.4	4.4	115U2A200
DST1402	3.9	1.6	11.7	4.9	2	075U2D200
DST1402	4.3	1.8	12.9	5.4	2.9	095U2B200
DST1402	5.7	2.4	17.1	7.1	9	142U2A200
DST1402	5.9	2.5	17.7	7.4	4	095U2C200
DST1402	6.5	2.7	19.5	8.1	6.7	115U2B200*
DST1403	7.5	3.1	22.5	9.4	5.1	095U2D200
DST1403	9	3.8	27	11.3	6.2	095U2E200
DST1403	9.4	3.9	28.2	11.8	9	115U2C200
DST1403	9.6	4.0	28.8	12.0	29.9	190U2A200
DST1404	10.8	4.5	32.4	13.5	15.6	142U2B200
DST1404	12.4	5.2	37.6	15.7	11.4	115U2D200
DST1405	15.3	6.4	45.9	19.1	13.8	115U2E200
DST1405	15.3	6.4	45.9	19.1	22.2	142U2C200
DST1405	19.3	8.0	57.7	24.0	28.8	142U2D200*

\* Motor output limited by drive rating

## DIGITAX ST UNIMOTOR FM @ 3000RPM COMBINATIONS

Table data based on 3000 rpm motors 3x Stall Torque

200V						
Drive Part No.	Stall Nm	Stall Amp	Peak Nm	Peak Amp	Inertia kg/cm <sup>2</sup>	Motor Part No.
DST1201	0.72	1.0	2.16	2.9	0.12	055E2A300
DST1201	1.2	1.3	3.6	3.9	0.7	075E2A300
DST1201	1.4	1.7	4.2	5.1	0.23	055E2B300
DST1202	2.1	2.4	6.3	7.3	0.34	055E2C300
DST1202	2.2	2.4	6.6	7.1	1.2	075E2B300
DST1202	2.3	2.5	6.9	7.4	1.7	095E2A300
DST1202	3.1	3.3	9.3	10.0	1.6	075E2C300
DST1202	3.5	3.8	10.5	11.3	4.4	115E2A300
DST1203	3.9	4.2	11.7	12.6	2	075E2D300
DST1203	4.3	4.6	12.9	13.9	2.9	095E2B300
DST1204	5.7	6.1	17.1	18.4	9	142E2A300
DST1204	5.9	6.3	17.7	19.0	4	095E2C300
DST1204	6.6	7.1	19.8	21.3	6.7	115E2B300
DST1204	7.1	7.6	21.1	22.7	5.1	095E2D300*

\* Motor output limited by drive rating

400V						
Drive Part No.	Stall Nm	Stall Amp	Peak Nm	Peak Amp	Inertia kg/cm <sup>2</sup>	Motor Part No.
DST1401	0.72	0.9	2.16	2.8	0.12	055U2A300
DST1401	1.2	0.8	3.6	2.3	0.7	075U2A300
DST1401	1.4	0.9	4.2	2.8	0.23	055U2B300
DST1401	2.1	1.3	6.3	4.0	0.34	055U2C300
DST1401	2.2	1.4	6.6	4.1	1.2	075U2B300
DST1401	2.3	1.4	6.9	4.3	1.7	095U2A300
DST1402	3.1	1.9	9.3	5.8	1.6	075U2C300
DST1402	3.5	2.2	10.5	6.6	4.4	115U2A300
DST1402	3.9	2.4	11.7	7.3	2	075U2D300
DST1402	4.3	2.7	12.9	8.1	2.9	095U2B300
DST1403	5.7	3.6	17.1	10.7	9	142U2A300
DST1403	5.9	3.7	17.7	11.1	4	095U2C300
DST1403	6.4	4.0	19.2	12.0	6.7	115U2B300*
DST1404	7.5	4.7	22.5	14.1	5.1	095U2D300
DST1404	9.0	5.6	27	16.9	6.2	095U2E300
DST1404	9.4	5.9	28.2	17.6	9	115U2C300
DST1405	9.6	6.0	28.8	18.0	29.9	190U2A300
DST1405	10.8	6.8	32.4	20.3	15.6	142U2B300
DST1405	12.4	7.8	37.6	23.5	11.4	115U2D300

\* Motor output limited by drive rating

## DIGITAX ST UNIMOTOR FM @ 4000RPM COMBINATIONS

Table data based on 4000 rpm motors 3x Stall Torque

200V						
Drive Part No.	Stall Nm	Stall Amp	Peak Nm	Peak Amp	Inertia kg/cm <sup>2</sup>	Motor Part No.
DST1201	0.72	1.7	2.16	5.1	0.12	055E2A600
DST1201	1.2	1.7	3.6	5.0	0.7	075E2A400
DST1202	1.4	3.3	4.2	10.0	0.23	055E2B600
DST1203	2.1	4.8	6.3	14.3	0.34	055E2C600
DST1202	2.2	3.1	6.6	9.2	1.2	075E2B400
DST1202	2.3	3.2	6.9	9.6	1.7	095E2A400
DST1203	3.1	4.3	9.3	12.9	1.6	075E2C400
DST1203	3.5	4.9	10.5	14.6	4.4	115E2A400
DST1203	3.9	5.4	11.7	16.3	2	075E2D400
DST1204	4.3	6.0	12.9	17.9	2.9	095E2B400
DST1204	5.5	7.6	16.4	22.8	9	142E2A400*

\* Motor output limited by drive rating

400V						
Drive Part No.	Stall Nm	Stall Amp	Peak Nm	Peak Amp	Inertia kg/cm <sup>2</sup>	Motor Part No.
DST1401	0.72	1.0	2.16	2.9	0.12	055U2A600
DST1401	1.2	1.0	3.6	3.0	0.7	075U2A400
DST1402	1.4	1.9	4.2	5.8	0.23	055U2B600
DST1402	2.1	2.7	6.3	8.0	0.34	055U2C600
DST1402	2.2	1.8	6.6	5.5	1.2	075U2B400
DST1402	2.3	1.9	6.9	5.8	1.7	095U2A400
DST1402	3.1	2.6	9.3	7.8	1.6	075U2C400
DST1403	3.5	2.9	10.5	8.8	4.4	115U2A400
DST1403	3.9	3.3	11.7	9.8	2	075U2D400
DST1403	4.3	3.6	12.9	10.8	2.9	095U2B400
DST1404	5.7	4.8	17.1	14.3	9	142U2A400
DST1404	5.9	4.9	17.7	14.8	4	095U2C400
DST1404	6.6	5.5	19.8	16.5	6.7	115U2B400
DST1405	7.5	6.3	22.5	18.8	5.1	095U2D400
DST1405	9.0	7.5	27	22.5	6.2	095U2E400
DST1405	9.4	7.8	28.2	23.5	9	115U2C400

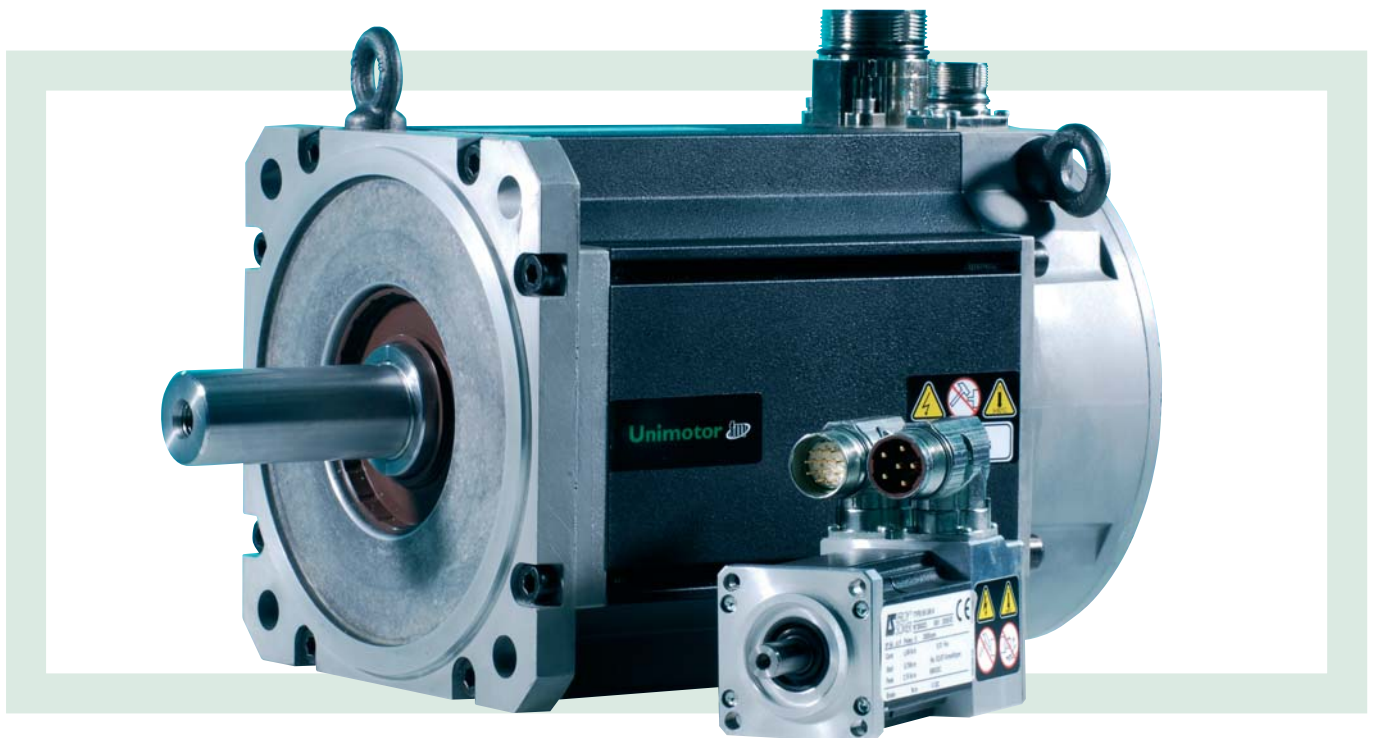

## DIGITAX ST UNIMOTOR FM @ 6000RPM COMBINATIONS

Table data based on 6000 rpm motors 3x Stall Torque

200V						
Drive Part No.	Stall Nm	Stall Amp	Peak Nm	Peak Amp	Inertia kg/cm <sup>2</sup>	Motor Part No.
DST1201	0.72	1.7	2.16	5.1	0.12	055E2A600
DST1202	1.2	2.6	3.6	7.7	0.7	075E2A600
DST1202	1.4	3.3	4.2	10.0	0.23	055E2B600
DST1203	2.1	4.8	6.3	14.3	0.34	055E2C600
DST1203	2.2	4.7	6.6	14.0	1.2	075E2B600
DST1203	2.3	4.9	6.9	14.7	1.7	095E2A600
DST1204	3.1	6.6	9.3	19.8	1.6	075E2C600
DST1204	3.5	7.4	10.5	22.3	4.4	115E2A600

400V						
Drive Part No.	Stall Nm	Stall Amp	Peak Nm	Peak Amp	Inertia kg/cm <sup>2</sup>	Motor Part No.
DST1401	0.72	1.0	2.16	2.9	0.12	055U2A600
DST1401	1.2	1.5	3.6	4.5	0.7	075U2A600
DST1402	1.4	1.9	4.2	5.8	0.23	055U2B600
DST1402	2.1	2.7	6.3	8.0	0.34	055U2C600
DST1403	2.2	2.8	6.6	8.3	1.2	075U2B600
DST1403	2.3	2.9	6.9	8.6	1.7	095U2A600
DST1403	3.1	3.9	9.3	11.6	1.6	075U2C600
DST1404	3.5	4.4	10.5	13.1	4.4	115U2A600
DST1404	3.9	4.9	11.7	14.6	2	075U2D600
DST1404	4.3	5.4	12.9	16.1	2.9	095U2B600
DST1405	5.7	7.1	17.1	21.4	9	142U2A600
DST1405	5.9	7.4	17.7	22.1	4	095U2C600
DST1405	6.4	8.0	19.2	24.0	6.7	115U2B600*

\* Motor output limited by drive rating



# TECHNICAL DATA FOR DIGITAX ST

## Model Reference

Model code explanation

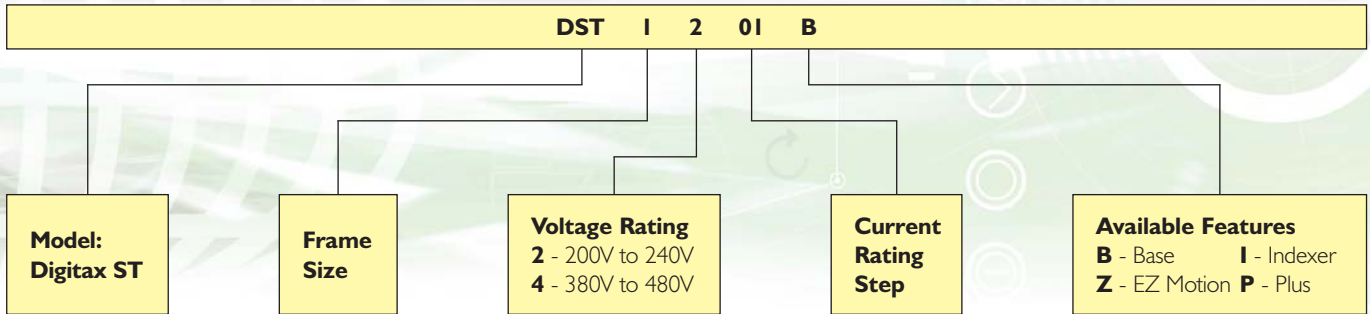

Drive Model Ratings				
Model	Rated Voltage (Volts)	No of input phases	Nominal current (Arms)	Peak current (Arms)
DST I 201	230	1	1.1	2.2
DST I 202	230	1	2.4	4.8
DST I 203	230	1	2.9	5.8
DST I 204	230	1	4.7	9.4
DST I 201	230	3	1.7	5.1
DST I 202	230	3	3.8	11.4
DST I 203	230	3	5.4	16.2
DST I 204	230	3	7.6	22.8
DST I 401	400	3	1.5	4.5
DST I 402	400	3	2.7	8.1
DST I 403	400	3	4	12
DST I 404	400	3	5.9	17.7
DST I 405	400	3	8	24

NOTE: The Drive selection should be based on Duty/Load Profile of the application.

Supply Requirements		
Model	Supply Voltage	Supply Frequency Range
DST I 20X	200V to 240V +/-10% single phase	48Hz to 65Hz
DST I 20X	200V to 240V +/-10% three phase	48Hz to 65Hz
DST I 40X	380V to 480V +/-10% three phase	48Hz to 65Hz

Internal Braking Resistor Option	
Part number	1299-0001
DC resistance at 25°C	70R
Average power	50W
Peak instantaneous power over 1ms at nominal resistance	2.2kW (230V) 8.7kW (400V)

## Drive Dimensions

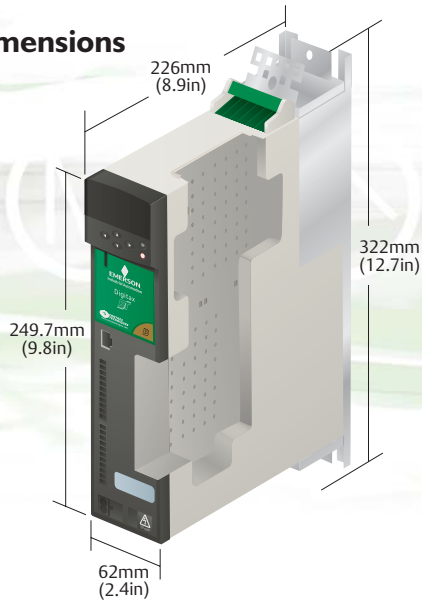

### Foot Mounted EMC Filters

Model	Voltage	Phases	Part Number
DST120X	230	1	4200-6000
DST120X	230	3	4200-6001
DST140X	400	3	4200-6002

### Other Options

Description	Part Number	Description	Part Number
Keypad	Digitax ST Keypad	CT Comms Cable RS232	4500-0087
Additional Standard Smartcard	2214-4246	CT Comms Cable USB	4500-0096
High Capacity Smartcard	2214-1006		

### General Drive Data

Type	Details	
IP Rating	IP20 (UL Type I / NEMA 1)	
Weight (net)	2.1 kg (4.6 lb) Excluding keypad and option modules	
Ambient operating temperature	0°C to 50°C (32°F to 122°F) Output current is derated at ambient temperatures >40°C (104°F)	
Operating humidity	Maximum relative humidity 95% non-condensing	
Altitude	0m to 3000m (9900ft). De-rate the maximum output current for the specified figure by 1% per 100m (330 ft) above 1000m (3300 ft).	
Power cycles per hour	60 starts per hour equally spaced	
Digital and Analogue I/O	1 Relay Output 3 Bi-directional Input/Outputs 1 High Resolution Analogue Input (16 bit + sign) 2 Analogue Outputs	3 Dedicated Inputs 1 Safe Torque Off Input 1 Standard Analogue Input (10 bit + sign) 1 Freeze Input (1μs)
Vibration	Tested in accordance to IEC60068-2-6/64	
Mechanical Shock	Tested in accordance to IEC60068-2-29	
Electromagnetic Immunity	Complies with EN61800-3 (2nd Environment)	
Electromagnetic Emissions	Complies with EN61800-3 (2nd Environment) with onboard filter. EN61000-6-3 and EN61000-6-4 with optional footprint EMC filter	

## Control Techniques Drive & Application Centres

### AUSTRALIA

Melbourne Application Centre  
T: +61 3 973 81777  
info.au@controltechniques.com

Sydney Drive Centre  
T: +61 2 9838 7222  
info.au@controltechniques.com

### AUSTRIA

Linz Drive Centre  
T: +43 7229 789480  
info.at@controltechniques.com

### BELGIUM

Brussels Drive Centre  
T: +32 1574 0700  
info.be@controltechniques.com

### BRAZIL

Emerson do Brazil Ltda  
T: +55 11 3618 6569  
info.br@controltechniques.com

### CANADA

Toronto Drive Centre  
T: +1 905 201 4699  
info.ca@controltechniques.com

Calgary Drive Centre  
T: +1 403 253 8738  
info.ca@controltechniques.com

### CHINA

Shanghai Drive Centre  
T: +86 21 5426 0668  
info.cn@controltechniques.com

Beijing Application Centre  
T: +86 10 856 31122 ext 820  
info.cn@controltechniques.com

### CZECH REPUBLIC

Brno Drive Centre  
T: +420 541 192111  
info.cz@controltechniques.com

### DENMARK

Copenhagen Drive Centre  
T: +45 4369 6100  
info.dk@controltechniques.com

### FRANCE\*

Angoulême Drive Centre  
T: +33 5 4564 5454  
info.fr@controltechniques.com

### GERMANY

Bonn Drive Centre  
T: +49 2242 8770  
info.de@controltechniques.com

Chemnitz Drive Centre  
T: +49 3722 52030  
info.de@controltechniques.com

Darmstadt Drive Centre  
T: +49 6251 17700  
info.de@controltechniques.com

### GREECE\*

Athens Application Centre  
T: +0030 210 57 86086/088  
info.gr@controltechniques.com

### HOLLAND

Rotterdam Drive Centre  
T: +31 184 420555  
info.nl@controltechniques.com

### HONG KONG

Hong Kong Application Centre  
T: +852 2979 5271  
info.hk@controltechniques.com

### INDIA

Chennai Drive Centre  
T: +91 44 2496 1123/  
2496 1130/2496 1083  
info.in@controltechniques.com

Pune Application Centre  
T: +91 20 2612 7956/2612 8415  
info.in@controltechniques.com

Kolkata Application Centre  
T: +91 33 2357 5302/2357 5306  
info.in@controltechniques.com

New Delhi Application Centre  
T: +91 11 2 576 4782/2 581 3166  
info.in@controltechniques.com

### IRELAND

Dublin Drive Centre  
T: +353 45 448200  
info.ie@controltechniques.com

### ITALY

Milan Drive Centre  
T: +39 02575 751  
info.it@controltechniques.com

Reggio Emilia Application Centre  
T: +39 02575 751  
info.it@controltechniques.com

Vicenza Drive Centre  
T: +39 0444 933400  
info.it@controltechniques.com

### KOREA

Seoul Application Centre  
T: +82 2 3483 1605  
info.kr@controltechniques.com

### MALAYSIA

Kuala Lumpur Drive Centre  
T: +603 5634 9776  
info.my@controltechniques.com

### REPUBLIC OF SOUTH AFRICA

Johannesburg Drive Centre  
T: +27 11 462 1740  
info.za@controltechniques.com

Cape Town Application Centre  
T: +27 21 556 0245  
info.za@controltechniques.com

### RUSSIA

Moscow Application Centre  
T: +7 495 981 9811  
info.ru@controltechniques.com

### SINGAPORE

Singapore Drive Centre  
T: +65 6468 8979  
info.sg@controltechniques.com

### SLOVAKIA

EMERSON A.S  
T: +421 32 7700 369  
info.sk@controltechniques.com

### SPAIN

Barcelona Drive Centre  
T: +34 93 680 1661  
info.es@controltechniques.com

Bilbao Application Centre  
T: +34 94 620 3646  
info.es@controltechniques.com

Valencia Drive Centre  
T: +34 96 154 2900  
info.es@controltechniques.com

### SWEDEN\*

Stockholm Application Centre  
T: +468 554 241 00  
info.se@controltechniques.com

### SWITZERLAND

Lausanne Application Centre  
T: +41 21 637 7070  
info.ch@controltechniques.com

Zurich Drive Centre  
T: +41 56 201 4242  
info.ch@controltechniques.com

### TAIWAN

Taipei Application Centre  
T: +886 22325 9555  
info.tw@controltechniques.com

### THAILAND

Bangkok Drive Centre  
T: +66 2580 7644  
info.th@controltechniques.com

### TURKEY

Istanbul Drive Centre  
T: +90 216 4182420  
info.tr@controltechniques.com

### UAE\*

Dubai Application Centre  
T: +971 4 883 8650  
info.ae@controltechniques.com

### UNITED KINGDOM

Telford Drive Centre  
T: +44 1952 213700  
info.gb@controltechniques.com

### USA

California Drive Centre  
T: +1 562 943 0300  
info.us@controltechniques.com

Charlotte Application Centre  
T: +1 704 393 3366  
info.us@controltechniques.com

Chicago Application Centre  
T: +1 630 752 9090  
info.us@controltechniques.com

Cleveland Drive Centre  
T: +1 440 717 0123  
info.us@controltechniques.com

Florida Drive Centre  
T: +1 239 693 7200  
info.us@controltechniques.com

Latin America Sales Office  
T: +1 305 818 8897  
info.us@controltechniques.com

Minneapolis US Headquarters  
T: +1 952 995 8000  
info.us@controltechniques.com

Oregon Drive Centre  
T: +1 503 266 2094  
info.us@controltechniques.com

Providence Drive Centre  
T: +1 401 541 7277  
info.us@controltechniques.com

Utah Drive Centre  
T: +1 801 566 5521  
info.us@controltechniques.com

## Control Techniques Distributors

### ARGENTINA

Euro Techniques SA  
T: +54 11 4331 7820  
eurotech@eurotechsa.com.ar

### BAHRAIN

Iftikhar Electrical Est.  
T: +973 271 1116  
ieepower@batalco.com.bh

### BULGARIA

BLS - Automation Ltd  
T: +359 32 968 007  
info@blsaautomation.com

### CENTRAL AMERICA

Mercado Industrial Inc.  
T: +1 305 854 9515  
rsaybe@mercadoindustrialinc.com

### CHILE

Ingeniería Y Desarrollo  
Tecnológico S.A  
T: +56 2741 9624  
idt@idt.cl

### COLOMBIA

Sistronic LTDA  
T: +57 2 555 60 00  
sistronic@telesat.com.co

### CROATIA

Koncar - MES d.d.  
T: +385 1 366 7273  
nabava@koncar-mes.hr

### CYPRUS

Acme Industrial Electronic  
Services Ltd  
T: +3572 5 332181  
acme@cytanet.com.cy

### EGYPT

Samiram  
T: +202 7360849/  
+202 7603877  
samiramz@samiram.com

### FINLAND

SKS Control  
T: +358 985 2661  
control@sksf.fi

### HUNGARY

Control-VH Kft  
T: +361 431 1160  
info@controlvh.hu

### ICELAND

Samey ehf  
T: +354 510 5200  
samey@samey.is

### INDONESIA

Pt Apikon Indonesia  
T: +65 6468 8979  
info.my@controltechniques.com

Pt Yua Esa Sempurna Sejahtera  
T: +65 6468 8979  
info.my@controltechniques.com

### ISRAEL

Dor Drives Systems Ltd  
T: +972 3900 7595  
info@dor1.co.il

### KENYA

Kassam & Bros Co. Ltd  
T: +254 2 556 418  
kassambros@africaonline.co.ke

### KUWAIT

Saleh Jamal & Company WLL  
T: +965 483 2358  
sjceng@allumlagroup.com

### LATVIA

EMT  
T: +371 760 2026  
janis@emt.lv

### LEBANON

Black Box Automation &  
Control  
T: +961 1 443773  
info@blackboxcontrol.com

### LITHUANIA

Elinta UAB  
T: +370 37 351 987  
sigitas@elinta.lt

### MALTA

Mekanika Limited  
T: +35621 442 039  
mfranca@gasan.com

### MEXICO

MELCSA  
T: +52 55 5561 1312  
melcsamx@iserve.net.mx  
SERVITECK, S.A de C.V.  
T: +52 55 5398 9591  
servitek@data.net.mx

### MOROCCO

Leroy Somer Maroc  
T: +212 22 354948  
lsmaroc@wanadooop.ma

### NEW ZEALAND

Advanced Motor Control, Ph.  
T: +64 (0) 274 363 067  
info.au@controltechniques.com

### PHILIPPINES

Control Techniques Singapore Ltd  
T: +65 6468 8979  
info.my@controltechniques.com

### POLAND

APATOR CONTROL Sp. z o.o  
T: +48 56 6191 207  
drives@apator.torun.pl

### PORTUGAL

Harker Summer S.A  
T: +351 22 947 8090  
drives.automation@harker.pt

### PUERTO RICO

Powermotion  
T: +1 787 843 3648  
dennis@powermotionpr.com

### QATAR

AFI Sitna Technologies  
T: +974 468 4442  
jp33@qatar.net.qa

### ROMANIA

Dor Drives International  
T: +40 21 337 3465  
dordrive@zappmobile.ro

### SAUDI ARABIA

A. Abunayyan Electric Corp.  
T: +9661 477 9111  
aec-salesmarketing@  
abunayyanguroup.com

### SERBIA & MONTENEGRO

Master Inzenjering d.o.o  
T: +381 24 551 605  
master@eunet.yu

### SLOVENIA

PS Logatec  
T: +386 1 750 8510  
ps-log@ps-log.si

### TUNISIA

SIA Ben Djemaa & CIE  
T: +216 1 332 923  
benjemmaa@planet.tn

### URUGUAY

Secoin S.A  
T: +5982 2093815  
secoin@adinet.com.uy

### VENEZUELA

Digimex Sistemas C.A.  
T: +58 243 551 1634

### VIETNAM

N.Duc Thinh  
T: +84 8 9490633  
infotech@nducthinh.com.vn