

User Guide

SM-I/O Lite ***SM-I/O Timer***

Solutions Module for:

- Unidrive SP
- Commander SK

Part Number: 0472-0004-03
Issue: 3

General Information

The manufacturer accepts no liability for any consequences resulting from inappropriate, negligent or incorrect installation or adjustment of the optional operating parameters of the equipment or from mismatching the variable speed drive with the motor.

The contents of this guide are believed to be correct at the time of printing. In the interests of a commitment to a policy of continuous development and improvement, the manufacturer reserves the right to change the specification of the product or its performance, or the contents of this guide, without notice.

All rights reserved. No parts of this guide may be reproduced or transmitted in any form or by any means, electrical or mechanical including photocopying, recording or by an information storage or retrieval system, without permission in writing from the publisher.

Drive software version

The SM-I/O Lite and SM-I/O Timer can only be used with the following drive software version:

Unidrive SP: \geq V01.07.00

Commander SK: \geq V01.00.00

I/O Lite/Timer Software Version: \geq V01.02.01

Contents

1	How to use this guide	4
1.1	Intended personnel	4
1.2	Information	4
2	Safety Information	5
2.1	Warnings, Cautions and Notes	5
2.2	Electrical safety - general warning	5
2.3	System design and safety of personnel	5
2.4	Environmental limits	6
2.5	Compliance with regulations	6
2.6	Motor	6
2.7	Adjusting parameters	6
3	Introduction	7
3.1	Features	7
3.2	Solutions Module identification	8
4	Installing the Solutions Module	9
4.1	Solutions Module slots	9
4.2	Installation	9
4.3	Terminal descriptions	11
4.4	Wiring, shield connections	12
5	Getting Started	17
5.1	Installation	17
6	Parameters	18
6.1	Introduction	18
6.2	Single line descriptions	19
6.3	Parameter descriptions	25
7	Diagnostics	35
7.1	Unidrive SP	35
7.2	Commander SK	36
8	Terminal data	37
8.1	Option to drive update times	39

1 How to use this guide

1.1 Intended personnel

This guide is intended for personnel who have the necessary training and experience in system design, installation, commissioning and maintenance.

1.2 Information

This guide contains information covering the identification of the Solutions Module, terminal layout for installation, fitting of the Solutions Module to the drive, parameter details and diagnosis information. Additional to the aforementioned are the specifications of the Solutions Module.

2 Safety Information

2.1 Warnings, Cautions and Notes



A **Warning** contains information, which is essential for avoiding a safety hazard.



A **Caution** contains information, which is necessary for avoiding a risk of damage to the product or other equipment.

NOTE A **Note** contains information, which helps to ensure correct operation of the product.

2.2 Electrical safety - general warning

The voltages used in the drive can cause severe electrical shock and/or burns, and could be lethal. Extreme care is necessary at all times when working with or adjacent to the drive.

Specific warnings are given at the relevant places in this User Guide.

2.3 System design and safety of personnel

The drive is intended as a component for professional incorporation into complete equipment or a system. If installed incorrectly, the drive may present a safety hazard.

The drive uses high voltages and currents, carries a high level of stored electrical energy, and is used to control equipment which can cause injury.

Close attention is required to the electrical installation and the system design to avoid hazards either in normal operation or in the event of equipment malfunction. System design, installation, commissioning and maintenance must be carried out by personnel who have the necessary training and experience. They must read this safety information and this User Guide carefully.

The STOP and SECURE DISABLE functions of the drive do not isolate dangerous voltages from the output of the drive or from any external option unit. The supply must be disconnected by an approved electrical isolation device before gaining access to the electrical connections.

With the sole exception of the SECURE DISABLE function, none of the drive functions must be used to ensure safety of personnel, i.e. they must not be used for safety-related functions.

Note that the SECURE DISABLE function is only available as standard on the Unidrive SP. The Commander SK does not have a SECURE DISABLE input.

Careful consideration must be given to the functions of the drive which might result in a hazard, either through their intended behaviour or through incorrect operation due to a fault. In any application where a malfunction of the drive or its control system could lead to or allow damage, loss or injury, a risk analysis must be carried out, and where necessary, further measures taken to reduce the risk - for example, an over-speed protection device in case of failure of the speed control, or a fail-safe mechanical brake in case of loss of motor braking.

The SECURE DISABLE function and secure input meet the requirements of EN954-1 category 3 for the prevention of unexpected starting of the drive. They may be used in a safety-related application. **The system designer is responsible for ensuring that the complete system is safe and designed correctly according to the relevant safety standards.**

2.4 Environmental limits

Instructions in the *Unidrive SP User Guide*, *Commander SK Getting Started Guide* and *Commander SK Technical Data Guide* regarding transport, storage, installation and use of the drive must be complied with, including the specified environmental limits. Drives must not be subjected to excessive physical force.

2.5 Compliance with regulations

The installer is responsible for complying with all relevant regulations, such as national wiring regulations, accident prevention regulations and electromagnetic compatibility (EMC) regulations. Particular attention must be given to the cross-sectional areas of conductors, the selection of fuses or other protection, and protective earth (ground) connections.

The *Unidrive SP User Guide* and *Commander SK EMC Guide* contain instructions for achieving compliance with specific EMC standards.

Within the European Union, all machinery in which this product is used must comply with the following directives:

98/37/EC: Safety of machinery.

89/336/EEC: Electromagnetic Compatibility.

2.6 Motor

Ensure the motor is installed in accordance with the manufacturer's recommendations. Ensure the motor shaft is not exposed.

Standard squirrel cage induction motors are designed for single speed operation. If it is intended to use the capability of the drive to run a motor at speeds above its designed maximum, it is strongly recommended that the manufacturer is consulted first.

Low speeds may cause the motor to overheat because the cooling fan becomes less effective. The motor should be fitted with a protection thermistor. If necessary, an electric forced vent fan should be used.

The values of the motor parameters set in the drive affect the protection of the motor. The default values in the drive should not be relied upon.

It is essential that the correct value is entered in the motor rated current parameter:

Pr **0.46** for Unidrive SP and Pr **06** in Commander SK. This affects the thermal protection of the motor.

2.7 Adjusting parameters

Some parameters have a profound effect on the operation of the drive. They must not be altered without careful consideration of the impact on the controlled system.

Measures must be taken to prevent unwanted changes due to error or tampering.

3 Introduction

3.1 Features

The SM-I/O Lite and SM-I/O Timer are Solutions Modules that can be used on the following products:

- Unidrive SP
- Commander SK

The connections between the Solutions Module and the drive are made via the drive connector. Connections from external equipment to the Solutions Module are made via a 3-way plugable screw connector for the relay and a 12-way plugable connector for the digital and analogue I/O and the reference encoder.

3.1.1 SM I/O Lite

- 1 x analogue input - bi-polar voltage or uni-polar current
- 1 x analogue output - uni-polar voltage or current
- 3 x digital inputs
- Quadrature reference encoder input
- 1 x +24V user supply
- 1 x +5V reference encoder supply
- 2 x 0V
- Status relay

3.1.2 SM I/O Timer

- 1 x analogue input - bi-polar voltage or uni-polar current
- 1 x analogue output - uni-polar voltage or current
- 3 x digital inputs
- Quadrature reference encoder input
- 1 x +24V user supply
- 1 x +5V reference encoder supply
- 2 x 0V
- Status relay
- Real time clock
- Year, month, day, hour, minute, second, date, daylight saving mode.

NOTE The reference encoder input on the SM-I/O Lite and SM-I/O Timer will not function when used on Unidrive SP.

Figure 3-1 SM-I/O Lite / SM-I/O Timer

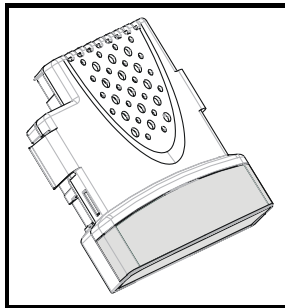

3.2 Solutions Module identification

The SM-I/O Lite and SM-I/O Timer can be identified by:

1. The label located on the underside of the Solutions Module.
2. The colour coding across the front of the Solutions Module.

SM-I/O Lite: Dark yellow

SM-I/O Timer: Dark red

Figure 3-2 SM-I/O Lite and SM-I/O Timer labels

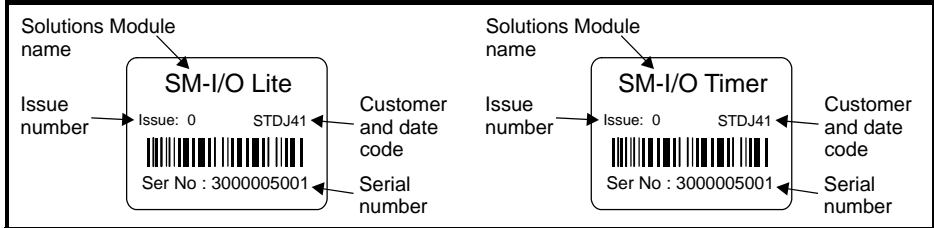

3.2.1 Date code format

The date code is split into two sections: a letter followed by a number.

The letter indicates the year, and the number indicates the week number (within the year) in which the Solutions Module was built.

The letters go in alphabetical order, starting with A in 1990 (B in 1991, C in 1992 etc.).

Example:

A date code of L35 would correspond to week 35 of year 2002.

4 Installing the Solutions Module

4.1 Solutions Module slots



Before installing the Solutions Module, refer to Chapter 2 *Safety Information* on page 5.

Unidrive SP

Three Solutions Module slots are available on Unidrive SP. The Solutions Module can be plugged into any of these slots but it is recommended that slot 3 be used for the first Solutions Module, then slot 2 and then slot 1. This ensures the maximum mechanical support for the Solutions Module once fitted.

See Figure 4-2.

Commander SK

One Solutions Module slot is available on Commander SK. See Figure 4-4 respectively.

4.2 Installation

1. Before installing a Solutions Module in any drive, ensure the AC supply has been disconnected for at least 10 minutes.
2. Ensure that on the Unidrive SP the +24V and low voltage DC power supplies have been disconnected from the drive for at least 10 minutes if used.
3. Check that the exterior of the Solutions Module is not damaged and the multiway connector on the underside of the module is free from dirt and debris.
4. Do not install a damaged or dirty Solutions Module in the drive.
5. Remove the terminal cover from the drive as shown in Figure 4-1, Figure 4-3.
6. Position the drive connector of the Solutions Module over the appropriate connector of the drive and push downwards until it locks into place. Make any wiring connections as appropriate.

On Commander SK only, ensure that the plastic tab which covers the drive's Solutions Module connector is removed before fitting any option. See Figure 4-3.

Figure 4-1 Removing the Uni SP terminal cover **Figure 4-2 Fitting and removing a Solutions Module into the Unidrive SP**

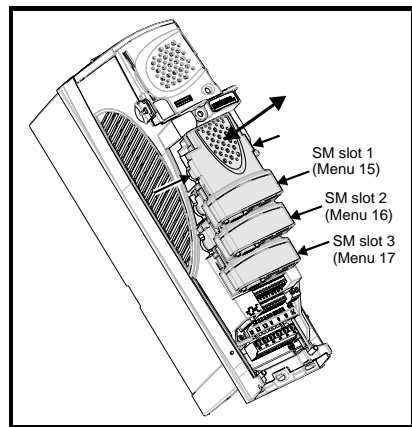
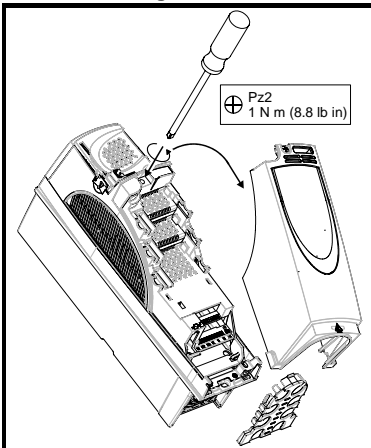

Figure 4-3 Removing the Commander SK terminal cover

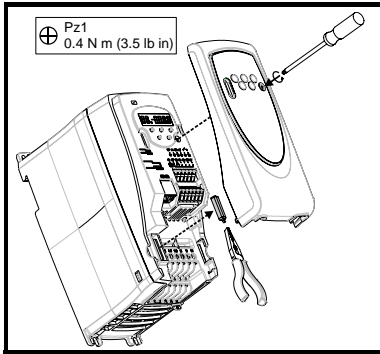
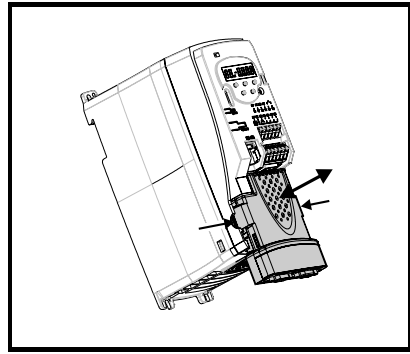

Figure 4-4 Fitting and removing a Solutions Module into the Commander SK



7. Re-fit the terminal cover to the drive by reversing the procedure shown in Figure 4-1, Figure 4-3.
8. Connect the AC supply to the drive.

Unidrive SP

9. When a Solutions Module is fitted to a Unidrive SP for the first time, as the drive is powered-up, the drive will trip on SL1.dF or SL2.dF or SL3.dF depending on which slot the Solutions Module is fitted to. A parameter save must be performed. Set Pr **xx.00** = 1000 (or 1001 in the case of solely using the 24V back-up power supply) and press the Stop/Reset button. If a parameter save is not performed, the drive will trip on the above trips the next time the drive is powered up.

NOTE When using the 24V back-up power supply only, the SLx.dF trip will not occur (as the drive is already displaying a UU trip).

NOTE When fitting two or more Solutions Modules simultaneously, the SLx.dF trip is only applicable to the module fitted in the lowest numerical slot.

NOTE If an SLx.dF trip is not seen after the first power-up, the Solutions Module is not fitted properly to the drive. Power down the drive, remove and re-fit the Solutions Module.

10. To access the advanced parameters refer to the *Unidrive SP User Guide*.
11. Check that Menu 15 (slot 1), 16 (slot 2), or 17 (slot 3) parameters are now available (depending on which slot is used).
12. Check that Pr **15.01**, Pr **16.01** or Pr **17.01** shows the correct code for the SM-I/O Lite or the SM-I/O Timer:
 - SM-I/O Lite: 207
 - SM-I/O Timer: 203

Commander SK

9. When a Solutions Module is fitted to a Commander SK for the first time, as the drive is powered-up, the drive will trip on SL.dF. Press the STOP/RESET button to clear the trip. The Commander SK automatically save the Solutions Module identity details to memory which will avoid any future SL.dF trips.
10. To access the advanced parameters refer to the *Commander SK Getting Started Guide*.

NOTE If an SL.dF trip is not seen after the first power-up, the Solutions Module is not fitted properly to the drive. Power down the drive, remove and re-fit the Solutions Module.

11. Check that Menu 15 parameters are now available.
12. Check that Pr **15.01** shows the correct code for the SM-I/O Lite or the SM-I/O Timer:
 - SM-I/O Lite: 207
 - SM-I/O Timer: 203

All products

13. Power the drive down and back up. The Solutions Module is now ready for programming.

NOTE If the Solutions Module is changed for another, the drive will trip as in step 9. Follow the above procedure.

14. If the checks in steps 11 and 12 fail, either the Solutions Module is not fully inserted, or it is faulty.
15. If a trip code is now present refer to *Chapter 7 Diagnostics* on page 35.

4.3 Terminal descriptions

Figure 4-5 SM-I/O Lite and SM-I/O Timer terminals

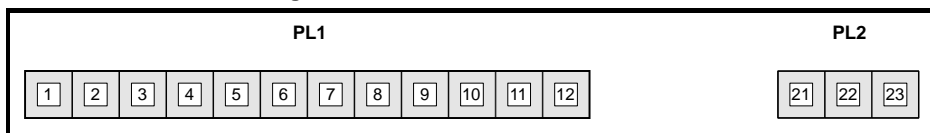

WARNING Provide fuse or other over-current protection in the relay circuit.

Table 4-1 Terminal descriptions

PL1 Term	Function	PL1 Term	Function	PL2	Function
1	0V common	7	Digital input 3 / Encoder B*	21	Relay 1
2	Analogue input	8	Encoder B\	22	Not connected
3	Analogue output	9	Encoder A	23	Relay 2
4	+24V	10	Encoder A\		
5	Digital input 1	11	0V		
6	Digital input 2	12	Encoder +5V		

*When terminal 7 is used as an encoder input, digital input 3 is not available

Figure 4-6 Reference encoder connections

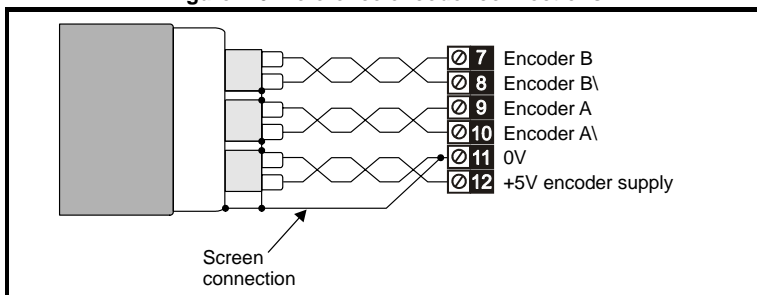

NOTE Refer to Chapter 4.4.5 *Reference encoder input specification (Commander SK)* on page 15 for encoder input specification and Chapter 8 *Terminal data* on page 37 for terminal data.

4.4 Wiring, shield connections

Shielding considerations are important for PWM drive installations due to high voltages and currents present in the output circuit with a very wide frequency spectrum, typically from 0 to 20 MHz. Reference encoder inputs are liable to be disturbed if careful attention is not given to managing the cable shields.

Reference encoder mounting methods

There are three methods for mounting a reference encoder on to a motor:

1. Galvanic isolation between reference encoder and motor
2. Galvanic isolation between reference encoder circuit and reference encoder body
3. No isolation

4.4.1 Reference encoder with galvanic isolation from motor

When galvanically isolated, the reference encoder is mounted to the motor with isolation fitted between the motor housing/shaft and the reference encoder as shown in Figure 4-7.

Figure 4-7 Galvanic Isolation from motor

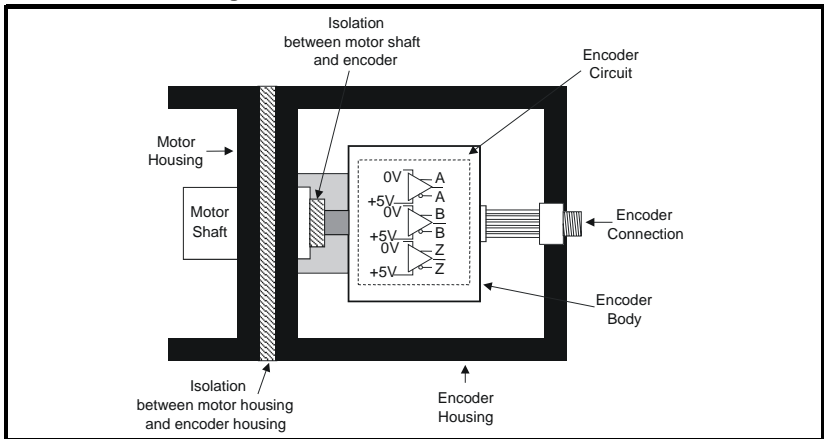

With this preferred method of mounting, noise current is prevented from passing from the motor housing into the reference encoder housing and hence into the motor cable. The ground connection of the cable shield is optional. This may be required to comply with safety measures or to reduce radiated radio frequency emissions from either the drive or reference encoder.

4.4.2 Reference encoder circuit with galvanic isolation from reference encoder body

In this case, the reference encoder is mounted directly on to the motor housing with contact being made between the motor housing/shaft and reference encoder as shown in Figure 4-8. With this mounting method, the reference encoder internal circuits are exposed to electrical noise from the motor housing through stray capacitance, and they must be designed to withstand this situation. However, this arrangement still prevents large noise currents from flowing from the motor body into the reference encoder cable. The ground connection of the cable shield is optional. This may be required to comply with safety measures or to reduce radiated radio frequency emissions from either the drive or reference encoder.

Figure 4-8 Reference encoder galvanically isolated from reference encoder body

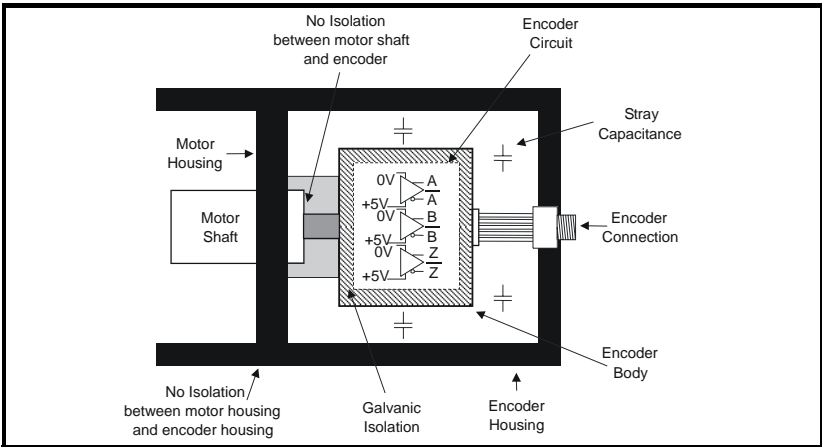

4.4.3 No Isolation

In this case, the reference encoder 0V connection may be permanently connected to the housing as in Figure 4-9. This has an advantage that the reference encoder body can form a shield for its internal circuits. However, it permits noise current from the motor body to flow into the reference encoder cable shield. A good quality shielded cable correctly terminated protects the data against this noise current, but much more care is needed in ensuring correct cable management than for the isolated cases above.

Figure 4-9 No isolation

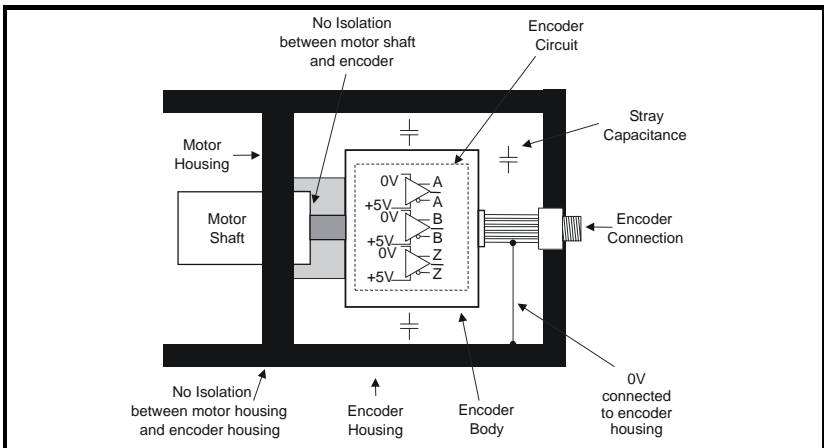

4.4.4 Cable requirements

All mounting methods

- Shield connection at drive terminals to 0V
- Shield connection at reference encoder 0V
- It is recommended that the shielded cable is run in one continuous length from the reference encoder to the drive. This avoids the injection of noise at intermediate connections (pigtailed) and maximises the shielding benefits.

- The shield connections (pigtailed) to the drive and reference encoder should be kept as short as possible.

Mounting with no isolation

- Shield connections to ground at both ends of the reference encoder cable. The connection must be made by direct fixing of the cable to the grounded metal parts i.e. the reference encoder body and the drive grounding bracket as illustrated in Figure 4-11. Pigtailed must be avoided. The outer sheath of the cable should be stripped back enough to allow for the ground clamps to be fitted. The shield connection should not be broken. The ground clamps should be located as close as possible to the drive and reference encoder.
- It is essential that the shielded cable be run in one continuous length between the drive and the reference encoder to avoid the injection of noise at intermediate connections (pigtailed) and to maximise the shielding benefit.



In this case under no circumstances must the cable shield connection be omitted at either end of the cable, since the noise voltage may well be sufficient to destroy the line driver and receiver chips in the reference encoder and the drive.

Cable shield ground connections

For all mounting methods, grounding of the feedback cable shields has added benefits. It can protect the drive and reference encoder from induced fast transients and prevent radiated radio-frequency emissions. However it is essential that it be carried out in the correct manor as explained above and shown in Figure 4-11



Connecting the cable shield to ground at both ends carries the risk that an electrical fault might cause excessive power current to flow in the cable shield and overheat the cable. There must be an adequately rated safety ground connection between the motor/reference encoder and the drive.

Recommended shielded cable

The recommended cable for feedback signals is shielded twisted pair with an overall shield as shown in Figure 4-10.

Figure 4-10 Recommended shielded cable

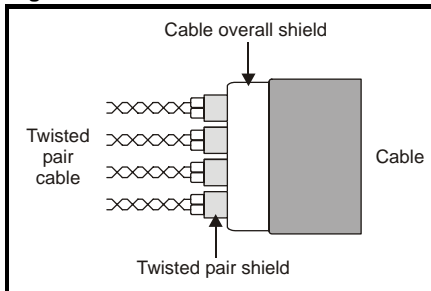

Using this type of cable also allows for the connection of the outer shield to ground and the inner shields to 0V alone at both drive and reference encoder end, when required.

NOTE

Ensure that feedback cables are kept as far away as possible from power cables and avoid parallel routing.

Figure 4-11 Feedback cable connections

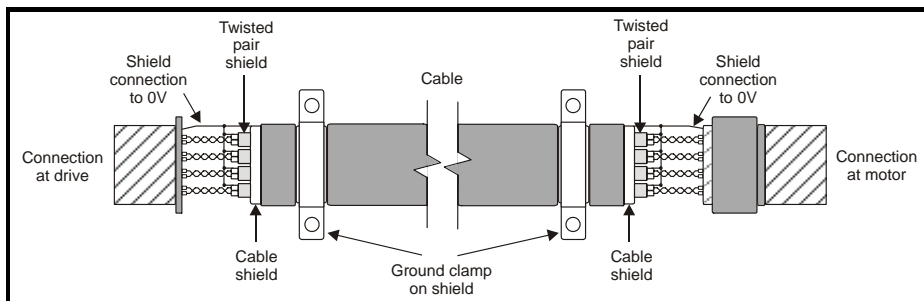

4.4.5 Reference encoder input specification (Commander SK)

An incremental reference encoder connected to A (terminal 9), A\ (terminal 10), B (terminal 7), B\ (terminal 8)

The reference encoder input will count non-differential inputs with connections to terminal 9 (A) and terminal 7 (B).

The reference encoder input will count a frequency and direction (F and D) signal:
F on terminal 9 (A)

D on terminal 7 (B) or terminal 8 (B) depending on the polarity of the D signal.

NOTE When using the reference encoder input for a F and D signal, Pr **15.58** (Drive encoder reference scaling) must be set to 2.

Reference encoder types

CMOS

TTL

NOTE When using a TTL reference encoder, an additional resistor as shown in Figure 4-12 must be used for A\ and B\ (A separate resistor is required for each of the two encoder lines.)

Figure 4-12

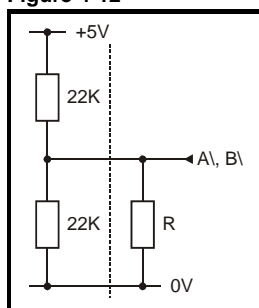

To calculate R (Ω):

$$R = \frac{22000V}{5 - 2V}$$

Where:

V = TTL voltage sensitivity (usually 2V)

Reference encoder supply

A +5V reference encoder can be used when supplied by the reference encoder +5V supply. When using an external supply, a +12V reference encoder may be used.

How to use this guide
Safety Information
Introduction
Installing the Solutions Module
Getting Started
Parameters
Diagnostics
Terminal data

4.4.6 Reference encoder limitations of use

The reference encoder input on the SM-I/O Lite and SM-I/O Timer is not a true quadrature reference encoder input and is only to be used as a digital reference input for basic feedback for speed following.

Therefore it is not recommended for use in applications that operate close to zero speed or require accurate positioning. Operation close to zero speed could lead to miscounting of pulses.

5 Getting Started

5.1 Installation



WARNING

The control circuits are isolated from the power circuits in the drive by basic insulation only, as specified in IEC60664-1. The installer must ensure that the external control circuits are isolated from human contact by at least one layer of insulation rated for use at the AC supply voltage.

If the control circuits are to be connected to other circuits classified as Safety Extra Low Voltage (SELV) (e.g. a personal computer) an additional isolating barrier must be included in order to maintain the SELV classification.



WARNING

The above warning also applies to the PCB edge connector for the optional Solutions Modules. To allow a Solutions Module to be fitted to Commander SK, a protective cover must be removed to allow access to the PCB edge connector See Figure 4-3 on page 10

This protective cover provides protection from direct contact of the PCB edge connector by the user. When this cover is removed and a Solutions Module fitted, the Solutions Module provides the protection from direct contact by the user. If the Solutions Module is then removed, this PCB edge connector becomes exposed. The user is required to provide protection in this case, to protect against direct contact of this PCB edge connector.

Reference encoder feedback data is transmitted from a reference encoder as low voltage digital signals. Ensure that the electrical noise from the drive or motor does not adversely affect the reference encoder feedback. Ensure that the drive and motor are connected as per the instructions the *Commander SK EMC Guide*

Table 5-1 SM-I/O Lite / SM-I/O Timer set-up

Action	Detail
Before power up	Ensure: <ul style="list-style-type: none"> • Drive enable signal is not given (terminal B4) • Run signal is not given • Solutions Module is fitted correctly • Feedback device is fitted correctly
Power up drive	Ensure: <ul style="list-style-type: none"> • The drive displays 'ih' (for SK), inh (for SP) • If the drive trips, see Chapter 7 <i>Diagnostics</i> on page 35.
Module identification	Slot 1 - menu 15 appears Pr 15.01 (SK & SP) Slot 2 - menu 16 appears Pr 16.01 (SP only) Slot 3 - menu 17 appears Pr 17.01 (SP only) 207 - SM I/O Lite 203 - SM I/O Timer
Set-up encoder lines per revolution (encoder can only be used on SK)	Enter lines per revolution Pr 15.52 0 - 512 1 - 1024 2 - 2048 3 - 4096

6 Parameters

6.1 Introduction

The parameters listed in this chapter are used for programming and monitoring the SM-I/O Lite and SM-I/O Timer.

NOTE

On the Unidrive SP, the same parameter structure is available in menu 15, 16 and 17 referring to slots 1, 2 and 3. Therefore, 'x' in the single line description table and the logic diagram represents either Menu 15, 16 or 17. However, for Commander SK it only represents Menu 15.



Before attempting to adjust any parameters, refer to Chapter 2 *Safety Information* on page 5.

Table 6-1 Key to parameter coding

Coding	Attribute
RW	Read/write: can be written by the user
RO	Read only: can only be read by the user
Bit	1 bit parameter
Bi	Bipolar parameter
Uni	Unipolar parameter
Txt	Text: the parameter uses text strings instead of numbers.
FI	Filtered: some parameters which can have rapidly changing values are filtered when displayed on the drive keypad for easy viewing.
DE	Destination: indicates that this parameter can be a destination parameter.
RA	Rating dependant: this parameter is likely to have different values and ranges with drives of different voltage and current ratings. This parameters is not transferred by smart cards when the rating of the destination drive is different from the source drive.
NC	Not cloned: not transferred to or from smart cards during cloning.
PT	Protected: cannot be used as a destination.
US	User save: saved in drive EEPROM when the user initiates a parameter save.
PS	Power-down save: automatically saved in drive EEPROM at power-down.

6.2 Single line descriptions

Parameter		Range(⇅)	Default(⇒)	Type					
x.01	Solutions Module ID	0 to 599		RO	Uni			PT	US
x.02	Solutions Module software version	0.0 to 99.99		RO	Uni		NC	PT	
x.03	Current loop loss indicator	OFF (0) or On (1)		RO	Bit		NC	PT	
x.04	Terminal T5 digital input 1 state	OFF (0) or On (1)		RO	Bit		NC	PT	
x.05	Terminal T6 digital input 2 state	OFF (0) or On (1)		RO	Bit		NC	PT	
x.06	Terminal T7 digital input 3 state	OFF (0) or On (1)		RO	Bit		NC	PT	
x.07	Relay state (Terminals T21 and T23)	OFF (0) or On (1)		RO	Bit		NC	PT	
x.08	Not used								
x.09	Not used								
x.10	Not used								
x.11	Not used								
x.12	Not used								
x.13	Not used								
x.14	Terminal T5 digital input 1 invert	OFF (0) or On (1)	OFF (0)	RW	Bit				US
x.15	Terminal T6 digital input 2 invert	OFF (0) or On (1)	OFF (0)	RW	Bit				US
x.16	Terminal T7 digital input 3 invert	OFF (0) or On (1)	OFF (0)	RW	Bit				US
x.17	Relay invert	OFF (0) or On (1)	OFF (0)	RW	Bit				US
x.18	Not used								
x.19	Real time clock daylight saving mode	OFF (0) or On (1)	0	RW	Bit				US
x.20	Digital I/O read word	0 to 120	0	RW	Uni		NC	PT	
x.21	Not used								
x.22	Not used								
x.23	Not used								
x.24	Terminal T5 digital input destination	Pr 0.00 to Pr 21.51	Pr 0.00	RW	Uni	DE		PT	US
x.25	Terminal T6 digital input destination	Pr 0.00 to Pr 21.51	Pr 0.00	RW	Uni	DE		PT	US
x.26	Terminal T7 digital input destination	Pr 0.00 to Pr 21.51	Pr 0.00	RW	Uni	DE		PT	US
x.27	Terminal T21/T23 relay 1 source	Pr 0.00 to Pr 21.51	Pr 0.00	RW	Uni	DE		PT	US
x.28	Not used								
x.29	Not used								
x.30	Real time clock update mode	0 to 2	0	RW	Uni				
x.31	Not used								
x.32	Not used								
x.33	Not used								
x.34	Real time clock minutes/seconds	00.00 to 59.59	00.00	RW	Uni			PT	
x.35	Real time clock days/hours	1.00 to 7.23	0.00	RW	Uni			PT	
x.36	Real time clock month/date	00.00 to 12.31	00.00	RW	Uni			PT	
x.37	Real time clock years	2000 to 2099	2000	RW	Uni			PT	
x.38	Analogue input 1 mode (Terminal T2)	0-20 (0), 20-0 (1), 4-20 (2), 20-4 (3), 4-20 (4), 20-4 (5), VoLt (6)	0-20(0)	RW	Txt				US
x.39	Analogue output 1 mode (Terminal T3)	0-20 (0), 20-0 (1), 4-20 (2), 20-4 (3), VoLt (4)	0	RW	Txt				US
x.40	Analogue input 1 level (Terminal T2)	±100 %		RO	Bi		NC	PT	
x.41	Analogue input 1 scaling (Terminal T2)	0.000 to 4.000	1.000	RW	Uni				US
x.42	Analogue input 1 invert (Terminal T2)	OFF (0) or On (1)	0	RW	Bit			PT	US
x.43	Analogue input 1 destination (Terminal T2)	Pr 1.01 to Pr 21.51	Pr 0.00	RW	Uni			PT	US
x.44	Not used								
x.45	Not used								

How to use this guide
Safety Information
Introduction
Installing the Solutions Module
Getting Started
Parameters
Diagnostics
Terminal data

Parameter		Range(⇅)	Default(⇔)	Type					
x.46	Not used								
x.47	Not used								
x.48	Analogue output 1 source (Terminal T3)	Pr 0.01 to Pr 21.51	Pr 0.00	RW	Uni			PT	US
x.49	Analogue output 1 scaling (Terminal T3)	0.000 to 4.000	1.000	RW	Uni				US
x.50	Solutions Module error status	0 to 255		RO	Uni		NC	PT	
x.51	Solutions Module software sub-version	0 to 99		RO	Uni		NC	PT	
x.52	Drive encoder lines per revolution	512 (0), 1024 (1), 2048 (2), 4096 (3)	1024 (1),	RW	Txt				US
x.53	Drive encoder revolution counter	0 to 65535		RO	Uni	FI	NC	PT	
x.54	Drive encoder position	0 to 65535 (1/2 ¹⁶ ths of a revolution)		RO	Uni	FI	NC	PT	
x.55	Drive encoder speed feedback	±32000 rpm		RO	Bi	FI	NC	PT	
x.56	Maximum drive encoder reference	0 to 32000 rpm	1500	RW	Uni				US
x.57	Drive encoder reference level	±100 %		RO	Bi			PT	
x.58	Drive encoder reference scaling	0.000 to 4.000	1.000	RW	Uni				US
x.59	Drive encoder reference destination	Pr 0.00 to Pr 21.51	Pr 0.00	RW	Uni	DE		PT	US
x.60	Encoder reset	OFF (0) or On (1)	OFF	RW	Bi				

Figure 6-1 Digital I/O logic diagram

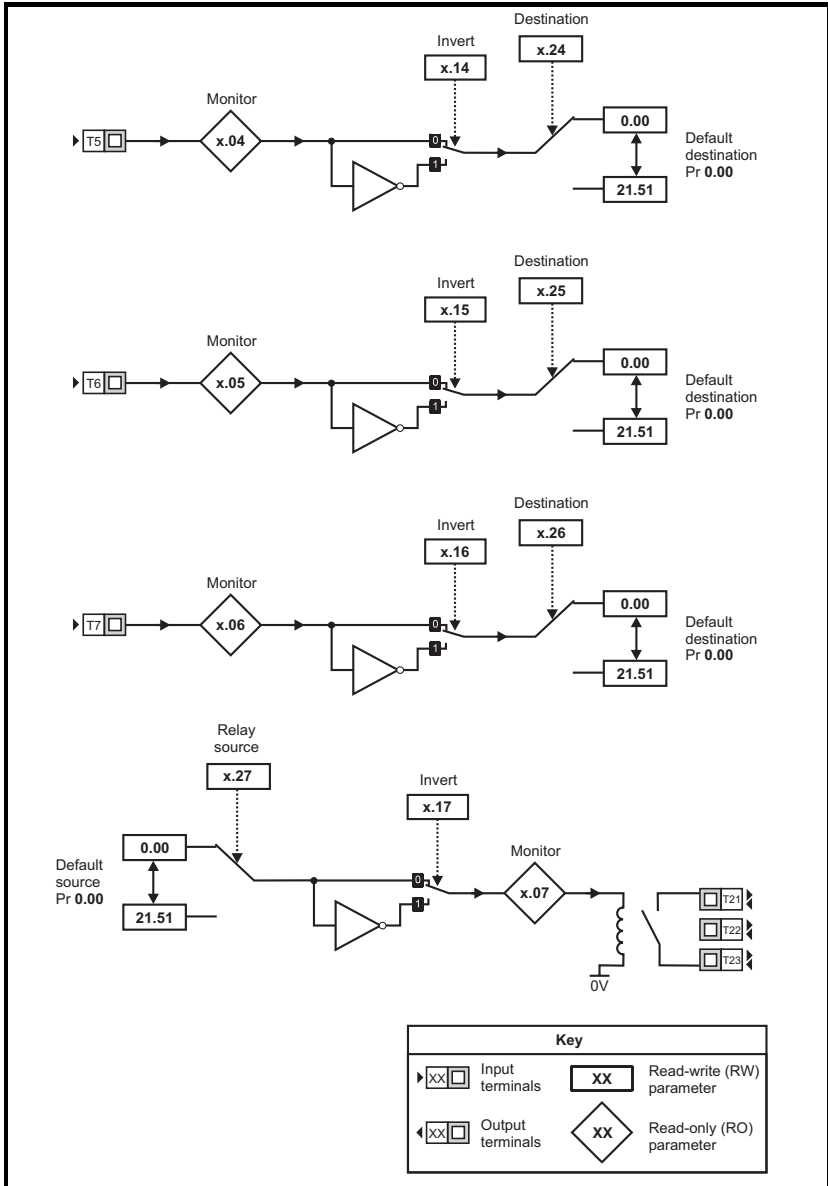

Figure 6-2 Analogue I/O logic diagram

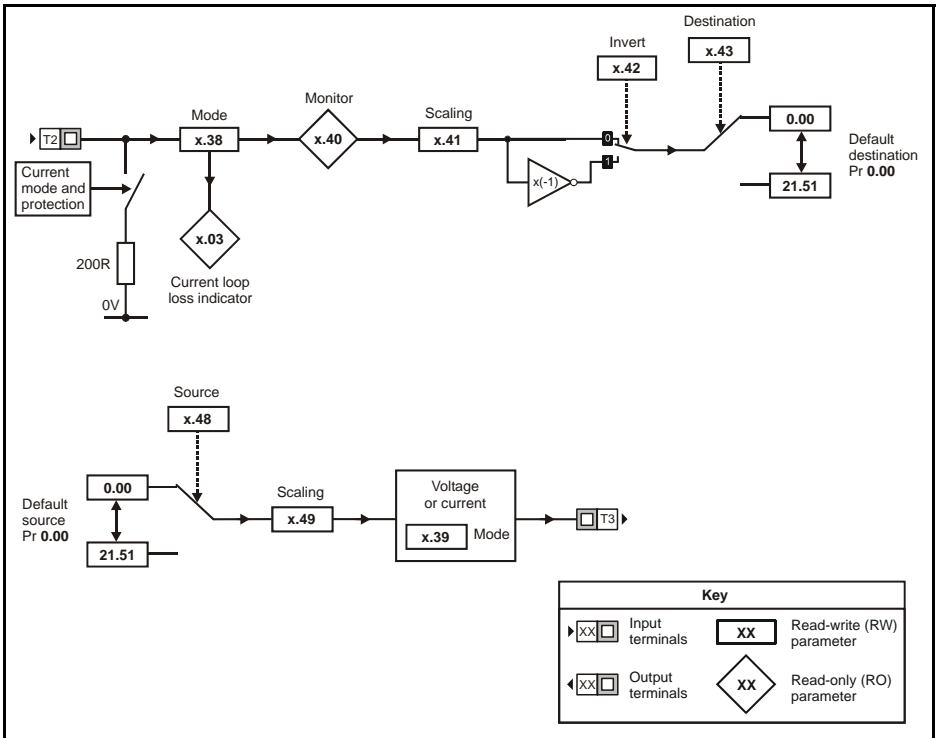

Figure 6-3 Encoder reference and real time clock logic diagram

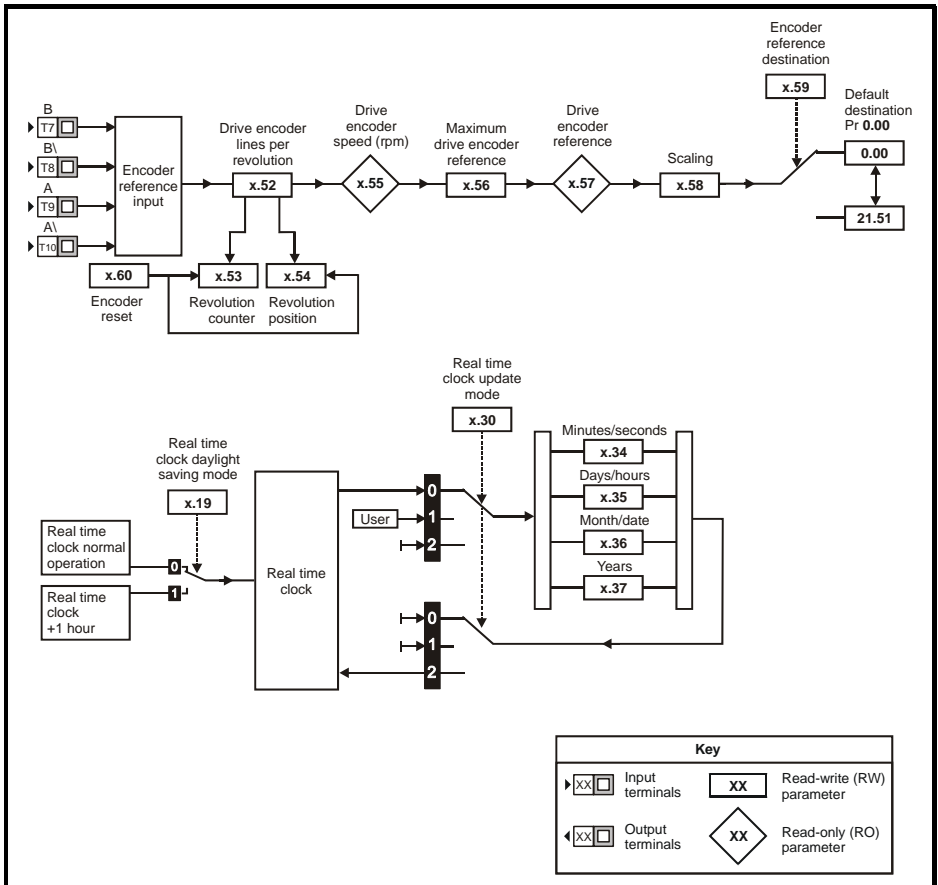
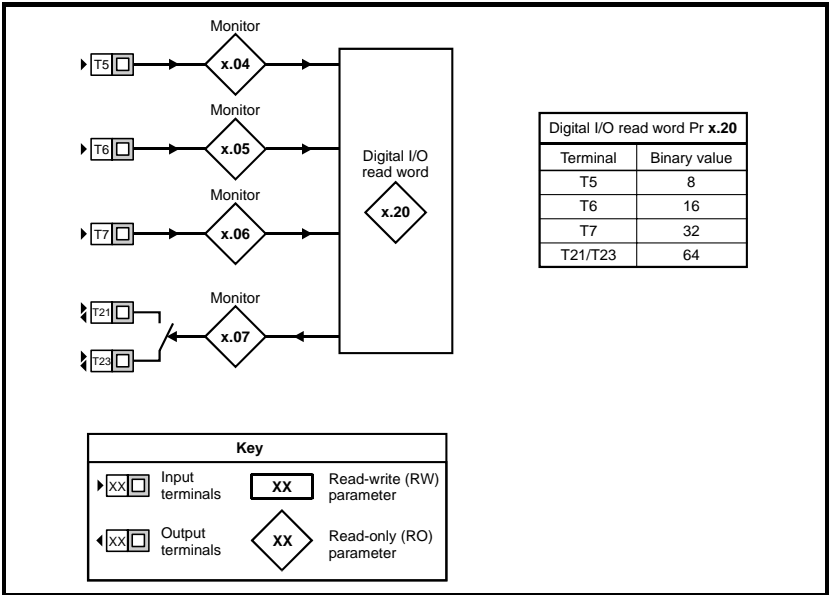

Figure 6-4 Digital I/O monitoring logic diagram



Digital I/O read word Pr x.20	
Terminal	Binary value
T5	8
T6	16
T7	32
T21/T23	64

6.3 Parameter descriptions

x.01		Option ID code								
RO	Uni						PT	US		
↕	0 to 599					⇒				
Update rate: Write on power-up										

On Unidrive SP the menu for the relevant slot appears for the new Solutions Module category with the default parameter values for the new category. For Commander SK it will always be menu 15.

When no Solutions Module is fitted in the relevant slot this parameter is zero. When a Solutions Module is fitted this parameter displays the identification code as shown below.

Code	Solutions Module	Category	Dumb module	Compatibility	
				Uni SP	Comm SK
0	No Solutions Module fitted				
101	SM-Resolver	Feedback	✓	✓	
102	SM-Universal Encoder Plus	Feedback		✓	
104	SM-Encoder Plus	Feedback	✓	✓	
201	SM-I/O Plus	Automation	✓	✓	
203	SM-I/O Timer	Automation		✓	✓
204	SM-PELV	Automation		✓	✓
206	SM-I/O 120V	Automation		✓	✓
207	SM-I/O Lite	Automation		✓	✓
301	SM-Applications	Automation		✓	
302	SM-Application Lite	Automation		✓	
303	SM-EZMotion	Automation		✓	
403	SM-Profibus DP	Fieldbus		✓	✓
404	SM-Interbus	Fieldbus		✓	✓
406	SM-CAN	Fieldbus		✓	
407	SM-DeviceNet	Fieldbus		✓	✓
408	SM-CANopen	Fieldbus		✓	✓
409	SM-SERCOS	Fieldbus		✓	
410	SM-Ethernet	Fieldbus		✓	✓
501	SM-SLM	Feedback		✓	

Unidrive SP

The new parameter values are not stored in the drive EEPROM until the user performs a parameter save by setting Pr **xx.00** to 1000 and pressing the stop/reset button. When parameters are saved by the user in the drive EEPROM, the option code of the currently fitted Solutions Module is saved in the drive EEPROM. If the drive is subsequently powered-up with a different Solutions Module fitted, or no Solutions Module is fitted when one was previously fitted, the drive will trip on SLx.dF or SLx.nF.

Commander SK

The new parameter values are stored automatically by the drive. If the drive is subsequently powered up with a different Solutions Module fitted, or no Solutions Module is fitted when one was previously fitted, the drive will trip on SL.dF or SL.nF.

x.02		Option software version							
RO	Uni					NC	PT		
⇕		00.00 to 99.99			⇒				
Update rate: Write on power-up									

This parameter shows the version of software programmed into the Solutions Module. The software sub version is displayed in Pr **x.51**.

These two parameters display the software version in the form of:

Pr **x.02** = xx.yy

Pr **x.51** = zz

x.03		Current loop loss indicator							
RO	Bit					NC	PT		
⇕		OFF(0) or On(1)			⇒				
Update rate: Background write									

If the Solutions Module analogue input is programmed in any of the modes 2 to 5 (see Pr **x.38** on page 29) then this bit is set if the current input falls below 3mA. This bit can be designated to a digital output to indicate that the current input is less than 3mA.

x.04		Terminal T5 digital input 1 state							
x.05		Terminal T6 digital input 2 state							
x.06		Terminal T7 digital input 3 state							
RO	Bit					NC	PT		
⇕		OFF(0) or On(1)			⇒				
Update rate: Background write									

0: OFF inactive

1: On active

Terminals T5 to T7 are three programmable digital inputs.

These parameters indicate the state of the digital input terminals.

If an external trip is required, then one of the terminals should be programmed to control the external trip parameter (Pr **10.32**), with the invert set to a On so that the terminal must be made active for the drive not to trip.

NOTE The digital inputs are set-up in positive logic only. This logic cannot be changed.

x.07		Relay state (Terminals T21 and T23)							
RO	Bit					NC	PT		
⇕		OFF(0) or On(1)			⇒				
Update rate: Background write									

0: OFF de-energised

1: On energised

This parameter indicates the state of the relay.

x.14		Terminal T5 digital input 1 invert							
x.15		Terminal T6 digital input 2 invert							
x.16		Terminal T7 digital input 3 invert							
RW	Bit							US	
⇕		OFF(0) or On(1)				⇒	OFF(0)		
Update rate: Background read									

Setting these parameters to a On causes the input sense to the destination parameter to be inverted.

x.17		Relay invert							
RW	Bit							US	
⇕		OFF(0) or On(1)				⇒	OFF(0)		
Update rate: Background read									

Setting this parameter to a 1 causes the relay sense to be inverted.

x.19		Real time clock daylight saving mode							
RW	Bit							US	
⇕		OFF(0) or On(1)				⇒	OFF(0)		
Update rate: Background read									

0: OFF Real time clock normal operation

1: On Real time clock + 1 hour

NOTE This parameter is not available on the SM-I/O Lite.

x.20		Digital I/O read word							
RW	Uni					NC	PT		
⇕		0 to 120				⇒	0		
Update rate: Background write									

This word is used to determine the status of the digital I/O by reading one parameter.

Pr **x.20** contains a binary value 'xx'. This binary value is determined by the state of Pr **x.04** to Pr **x.07**. So for example, if all terminals were active the value displayed in Pr **x.20** would be the sum of the binary values shown in the table, i.e. 120.

Binary value for xx	Digital I/O
1	
2	
4	
8	Terminal T5
16	Terminal T6
32	Terminal T7
64	Terminals T21 & T23
128	

x.24		Terminal T5 digital input destination							
x.25		Terminal T6 digital input destination							
x.26		Terminal T7 digital input destination							
RW	Uni		DE				PT	US	
⇕	Pr 0.00 to Pr 21.51					⇒	Pr 0.00		
Update rate: Read on drive reset									

Destination parameters define the parameter each of the programmable inputs is to control. Only parameters that are not protected can be controlled by the programmable digital inputs. If a non-valid parameter is programmed, the digital input is not routed anywhere.

x.27		Terminal T21 / T23 relay/ source							
RW	Uni		DE				PT	US	
⇕	Pr 0.00 to Pr 21.51					⇒	Pr 0.00		
Update rate: Read on drive reset									

This parameter defines the parameter to be represented by the status relay. Only unprotected parameters can be selected as a source for the relay output. If a non-valid parameter is programmed, then the relay will remain in the last known state.

x.30		Real time clock update mode							
RW	Uni								
⇕	0 to 2					⇒	0		
Update rate: Background read/write									

- 0: Real time clock parameters controlled by real time clock
- 1: Real time clock parameters controlled by user
- 2: Real time clock reads real time clock parameters and sets Pr **x.30** to 0

NOTE This parameter is not available on the SM-I/O Lite.

x.34		Real time clock minutes/seconds							
RW	Uni						PT		
⇕	00.00 to 59.59					⇒	00.00		
Update rate: Background read/write									

x.35		Real time clock days/hours							
RW	Uni						PT		
⇕	1.00 to 7.23					⇒	0.00		
Update rate: Background read/write									

x.36		Real time clock month/ date							
RW	Uni						PT		
⇕	00.00 to 12.31				⇒	00.00			
Update rate: Background read/write									

x.37		Real time clock years							
RW	Uni						PT		
⇕	2000 to 2099				⇒	2000			
Update rate: Background read/write									

NOTE Pr **x.34** to Pr **x.37** are not available on the SM-I/O Lite.

x.38		Analogue input 1 mode (Terminal T2)							
RW	Txt							US	
⇕	0-20(0), 20-0(1), 4-20(2), 20-4(3), 4-.20(4), 20-.4(5), VoLt(6)				⇒	0-20(0)			
Update rate: Background read									

Terminal T2 is a voltage/current reference input. The setting of this parameter configures the terminal to the required mode.

Value	SK Display	SP Display	Function
0	0-20	0-20	0 to 20mA
1	20-0	20-0	20 to 0mA
2	4-20	4-20.tr	4 to 20mA with trip on loss
3	20-4	20-4.tr	20 to 4mA with trip on loss
4	4-.20	4-20	4 to 20mA with no trip on loss
5	20-.4	20-4	20 to 4mA with no trip on loss
6	VoLt	VOLt	±10V

In modes 2 and 3, a current loop loss trip (SLX.Er on Unidrive SP and SL.Er on Commander SK) will be generated if the current input falls below 3mA, and Pr **x.50** will be set to a 2.

NOTE If 4-20 or 20-4 modes are selected and the drive trips on current loop loss (cL), analogue reference 2 cannot be selected if the current reference is <3mA.

If 4-.20 or 20-.4 modes are selected, Pr **x.03** will switch from a OFF to On to indicate that the current reference is <3mA.

NOTE If bi-polar operation is required, the -10V reference must be generated and supplied by an external power supply.

x.39		Analogue output 1 mode (Terminal T3)							
RW	Txt							US	
⇅	0-20(0), 20-0(1), 4-20(2), 20-4(3), VoLt(4)				⇒	0-20(0)			
Update rate: Background read									

Terminal T3 is a voltage/current output. The setting of this parameter configures the terminal for the required mode.

Value	Display	Function
0	0-20	0 to 20mA
1	20-0	20 to 0mA
2	4-20	4 to 20mA
3	20-4	20 to 4mA
4	VoLt	0 to +10V

x.40		Analogue input 1 level (Terminal T2)							
RO	Bi					NC	PT		
⇅	±100 %				⇒				
Update rate: Background write									

This parameter displays the level of the analogue signal present at analogue input 1.

In voltage mode, this is a bipolar voltage input where the input range is ±10V.

In current mode, this is a unipolar current input having a maximum measurable input of 20mA. The drive can be programmed to convert the measured current to any one of the defined ranges in Pr **x.38**. The selected range is converted to 0.0 - 100.0%.

x.41		Analogue input 1 scaling (Terminal T2)							
RW	Uni							US	
⇅	0.000 to 0.400				⇒	1.000			
Update rate: Background read									

This parameter is used to scale the analogue input if so desired. However in most cases it is not necessary as each input is automatically scaled such that for 100.0%, the destination parameters (defined by the settings of Pr **x.43**) will be at maximum.

x.42		Analogue input 1 invert (Terminal T2)							
RW	Bit						PT	US	
⇅	OFF(0) or On(1)				⇒	OFF(0)			
Update rate: Background read									

This parameter can be used to invert the analogue input reference (i.e. multiply the input scaling result by -1).

x.43		Analogue input 1 destination (Terminal T2)							
RW	Uni						PT	US	
↕	Pr 0.00 to Pr 21.51				⇒	Pr 0.00			
Update rate: Read on drive reset									

Only parameters that are not protected can be controlled by analogue inputs. If a non-valid parameter is programmed to the destination of an analogue input, the input is not routed anywhere. After a modification to this parameter, the destination is only changed when a reset is performed.

x.48		Analogue output 1 source (Terminal T3)							
RW	Uni						PT	US	
↕	Pr 0.00 to Pr 21.51				⇒	Pr 0.00			
Update rate: Read on drive reset									

The parameter required to be represented as an analogue signal by the analogue output on Terminal T3 should be programmed in this parameter. Only parameters that are not protected can be programmed as a source. If a non-valid parameter is programmed as a source, the output will remain at zero. After a modification to this parameter, the source is only changed when a reset is performed.

x.49		Analogue output 1 scaling (Terminal T3)							
RW	Uni							US	
↕	0.000 to 4.000				⇒	1.000			
Update rate: Background read									

This parameter can be used to scale the analogue output if so desired. However in most cases it is not necessary as the output is automatically scaled such that when the source parameter is at its maximum, the analogue output will be at its maximum.

x.50		Solutions Module error status							
RO	Uni					NC	PT		
↕	0 to 255				⇒				
Update rate: Background write									

The error status is provided so that only one option error trip is required for each Solutions Module slot. If an error occurs, the reason for the error is written to this parameter and the drive may produce an 'SLX.Er' trip on Unidrive SP (where X is the slot number), or 'SL.Er' trip on Commander SK. A value of zero indicates that the Solutions Module has not detected an error, a non-zero value indicates that an error has been detected. (See Chapter 7 *Diagnostics* for the meaning of the values in this parameter.) When the drive is reset, this parameter is cleared for the relevant Solutions Module.

This Solutions Module includes a temperature monitoring circuit. If the PCB temperature exceeds 65°C, the drive fan is forced to operate at full speed (for a minimum of 20s). If the temperature falls below 65°C, the fan can operate normally again. If the PCB temperature exceeds 70°C, the drive will trip on SLX.Er on Unidrive SP or SL.Er on Commander SK, and the error status is set to 74.

x.51		Solutions Module software sub-version									
RO	Uni						NC	PT			
↕	0 to 99					⇒					
Update rate: Write on power-up											

The Solutions Module includes a processor with software. The software version is displayed in Pr **x.02** and Pr **x.51** in the form Pr **x.02** = xx.yy and Pr **x.51** = zz.

Where:

xx specifies a change that affects hardware compatibility

yy specifies a change that affects product documentation

zz specifies a change that does not affect the product documentation

When a Solutions Module is fitted that does not contain software, both Pr **x.02** and Pr **x.51** appear as zero.

x.52		Drive encoder lines per revolution									
RW	Txt									US	
↕	512(0), 1024(1), 2048(2), 4096(3)					⇒	1024(1)				
Update rate: Background read/write											

0: 512 lines per revolution encoder

1: 1024 lines per revolution encoder

2: 2048 lines per revolution encoder

3: 4096 lines per revolution encoder

NOTE A change to this parameter only takes effect when the drive is disabled, stopped or tripped.

x.53		Drive encoder revolution counter									
RO	Uni	FI					NC	PT			
↕	0 to 65535 revolutions					⇒					
Update rate: Background write											

This parameter shows the revolutions count of the encoder reference.

NOTE With a reset command, the revolution counter is reset to zero.

x.54		Drive encoder position									
RO	Uni	FI					NC	PT			
↕	0 to 65535 revolutions (1/2 ¹⁶ ths of a revolution)					⇒					
Update rate: Background write											

This parameter shows the position of the encoder reference.

x.55		Drive encoder speed feedback									
RO	Bi	FI					NC	PT			
⇅	±32000 rpm					⇒					
Update rate: Background write											

This parameter shows the reference encoder speed in rpm provided that the set-up parameters for the drives reference encoder are correct.

x.56		Maximum drive encoder reference									
RW	Uni								US		
⇅	0 to 32000 rpm					⇒	1500				
Update rate: Background read											

This parameter limits the range of the encoder speed reference being used.

x.57		Drive encoder reference level									
RO	Bi							PT			
⇅	±100 %					⇒					
Update rate: Background write											

This parameter shows the percentage of the encoder reference level being used.

x.58		Drive encoder reference scaling									
RO	Uni								US		
⇅	0.000 to 4.000					⇒	1.000				
Update rate: Background read											

The encoder reference is scaled by the parameter before being sent to the encoder reference destination.

x.59		Drive encoder reference destination									
RW	Uni		DE					PT	US		
⇅	Pr 1.01 to Pr 21.51					⇒	Pr 0.00				
Update rate: Read on drive reset											

This parameter may be routed to any non-protected drive parameter.

After a modification to this parameter, the destination is only changed when a reset is performed

NOTE The reference encoder input will not function with Unidrive SP.

NOTE The reference encoder is only active with Commander SK if the output destination is routed to a valid unprotected parameter. If only the indicator parameters are required, the destination parameter should be routed to an unused valid parameter.

x.60		Encoder reset							
RW	Bit								
↕	OFF(0) or On(1)				⇒	OFF(0)			
Update rate: Encoder only: 16ms All I/So routed: 26ms									

Setting this bit parameter will reset the drive encoder revolution counter (Pr **x.53**) and drive encoder position (Pr **x.54**) to zero.

7 Diagnostics

7.1 Unidrive SP

Trip no.	String	Diagnosis																
200, 205, 210	SLX.HF	Solutions Module hardware fault Ensure Solutions Module is fitted correctly Return Solutions Module to supplier																
201, 206, 211	SLX.tO	Solutions Module watchdog time-out Press reset If the trip persists, contact the supplier of the drive																
202, 207, 212	SLX.Er	Error detected with Solutions Module where X is the slot number <table border="1" data-bbox="360 459 1008 694"> <thead> <tr> <th>Pr x.50</th> <th>Fault description</th> </tr> </thead> <tbody> <tr> <td>0</td> <td>No errors</td> </tr> <tr> <td>1</td> <td>Digital output short circuit</td> </tr> <tr> <td>2</td> <td>Current input too high or too low</td> </tr> <tr> <td>3</td> <td>Reference encoder supply over current</td> </tr> <tr> <td>4</td> <td>Solutions Module serial communications error</td> </tr> <tr> <td>5</td> <td>Real time clock error (SM-I/O Timer only)</td> </tr> <tr> <td>74</td> <td>Solutions Module over temperature (>70°C)</td> </tr> </tbody> </table>	Pr x.50	Fault description	0	No errors	1	Digital output short circuit	2	Current input too high or too low	3	Reference encoder supply over current	4	Solutions Module serial communications error	5	Real time clock error (SM-I/O Timer only)	74	Solutions Module over temperature (>70°C)
Pr x.50	Fault description																	
0	No errors																	
1	Digital output short circuit																	
2	Current input too high or too low																	
3	Reference encoder supply over current																	
4	Solutions Module serial communications error																	
5	Real time clock error (SM-I/O Timer only)																	
74	Solutions Module over temperature (>70°C)																	
203, 208, 213	SLX.nF	Solutions Module has been removed Ensure Solutions Module is fitted correctly Save parameters and reset drive Replace Solutions Module																
204, 209, 214	SLX.dF	Solutions Module fitted in slot X has changed Save parameters and reset																
215	SL.rtd	Drive mode has changed and Solutions Module parameter routing is now incorrect Press reset If the trip persists, contact the supplier of the drive																

For further information on the above trips, see Menu 10 in the *Unidrive SP Advanced User Guide*.

7.2 Commander SK

Trip no.	String	Diagnosis																
200	SL.HF	Solutions Module hardware fault Ensure Solutions Module is fitted correctly Return Solutions Module to supplier																
201	SL.tO	Solutions Module watchdog time-out Press reset If the trip persists, contact the supplier of the drive																
202	SL.Er	Error detected with Solutions Module <table border="1" data-bbox="360 354 1005 592"> <thead> <tr> <th>Pr 15.50</th> <th>Fault description</th> </tr> </thead> <tbody> <tr> <td>0</td> <td>No errors</td> </tr> <tr> <td>1</td> <td>Digital output short circuit</td> </tr> <tr> <td>2</td> <td>Current input too high or too low</td> </tr> <tr> <td>3</td> <td>Reference encoder supply over current</td> </tr> <tr> <td>4</td> <td>Solutions Module serial communications error</td> </tr> <tr> <td>5</td> <td>Real time clock error (SM-I/O Timer only)</td> </tr> <tr> <td>74</td> <td>Solutions Module over temperature (>70°C)</td> </tr> </tbody> </table>	Pr 15.50	Fault description	0	No errors	1	Digital output short circuit	2	Current input too high or too low	3	Reference encoder supply over current	4	Solutions Module serial communications error	5	Real time clock error (SM-I/O Timer only)	74	Solutions Module over temperature (>70°C)
Pr 15.50	Fault description																	
0	No errors																	
1	Digital output short circuit																	
2	Current input too high or too low																	
3	Reference encoder supply over current																	
4	Solutions Module serial communications error																	
5	Real time clock error (SM-I/O Timer only)																	
74	Solutions Module over temperature (>70°C)																	
203	SL.nF	Solutions Module has been removed Ensure Solutions Module is fitted correctly Replace Solutions Module																
204	SL.dF	Solutions Module fitted has changed Power down and back up																

For further information on the above trips, see Menu 10 in the *Commander SK Advanced User Guide*.

8 Terminal data

1 0V

2 Analogue input, either voltage or current	
Default setting	±10V bi-polar input
Voltage: Current	±10V bi-polar input: mA as parameter range (see Pr x.38 on page 29)
Parameter range	0-20, 20-0, 4-20, 20-4, 4-..20, 20-..4, VoLt
Scaling	Input range automatically scaled to parameter minimum and maximum
Input impedance	200Ω (current): 100kΩ (positive input voltage) : 18kΩ (negative input voltage)
Resolution	11 bit plus sign
Accuracy	2% for positive input voltage or current 4% for negative input voltage
Absolute maximum voltage range	+35V to -18V with respect to 0V common

3 Analogue output, either voltage or current	
Default setting	0 to +10V
Voltage: Current	0 to +10V: mA as parameter range (see Pr x.39 on page 30)
Parameter range	0-20, 20-0, 4-20, 20-4, 4-..20, 20-..4, VoLt
Scaling	0V represents zero value of parameter +10V represents the parameter maximum
Maximum output current	5mA
Resolution	13 bit
Accuracy	±2%
Protection	Tolerates continuous short circuit to 0V

4 +24V output	
Maximum output current	100mA
Protection	Tolerates continuous short circuit to 0V
Accuracy	±15%

5 Digital input 1	
6 Digital input 2	
7 Digital input 3 / Encoder B*	
Logic	Positive logic only
Voltage range	0 to +24V
Input impedance	6k8
Nominal threshold voltage	+10V
Absolute maximum voltage range	+35V to -18V with respect to 0V common

NOTE Digital inputs are positive logic only.

How to use this guide
Safety Information
Introduction
Installing the Solutions Module
Getting Started
Parameters
Diagnostics
Terminal data

8	Encoder B\	
9	Encoder A	
10	Encoder A\	
Maximum input frequency		55kHz quadrature 110kHz Frequency and direction
Maximum input voltage		Differential inputs up to 12V

NOTE The reference encoder input on the SM-I/O Lite and SM-I/O Timer will not function when used on Unidrive SP.

For further details, see section 4.4.5 *Reference encoder input specification (Commander SK)* on page 15 and section 4.4.6 *Reference encoder limitations of use* on page 16.

11	0V
-----------	-----------

12	+5V encoder output
Maximum output current	250mA
Protection	Tolerates continuous short circuit to 0V
Accuracy	±2%

21	Relay contact 1
22	Not connected
23	Relay contact 2
Contact voltage rating	240Vac 30Vdc
Contact maximum current rating	2Aac 240V 4Adc 30V resistive load 0.3Adc 30V inductive load (L/R = 40ms)
Contact minimum recommended rating	12V 100mA
Default contact condition	Open when power applied
Contact isolation	240Vac, over-voltage category II



Provide fuse or other over-current protection in relay circuit.



When the SM-I/O Lite or SM-I/O Timer is used with Commander SK, the relay terminals are exposed. To ensure protection to IP20 and prevent accidental contact with live connections, the following precautions are required:

- All terminal screws on live circuits are to be tightened
- Wire size not to exceed 12AWG or 4mm²
- Wire insulation to be stripped by no more than 8mm, or use protective ferrule

8.1 Option to drive update times

I/O description	Required update time (ms)	
	Unidrive SP	Commander SK
Background (mandatory)	1	5
Digital input 1	0.5	2
Digital input 2	0.5	2
Digital input 3 / Encoder input*	0.5	2
Relay output	0.5	2
Analogue input	0.5 / 2**	2 / 8**
Analogue output	0.5	3
Total update time for all	4 / 5.5**	18 / 24**
Encoder update rate	N/A	4 - 18ms

NOTE

* When the reference encoder input is used, digital input 3 is not available.

* The reference encoder input is not available on Unidrive SP

The total update time is the total update time for the option to drive and also the update rate for the destination parameter (see the *Commander SK Advanced User Guide*).

Examples:

Digital input 1 (2ms) + mandatory (5ms) = 7ms

Destination parameter is Pr **6.30** (run forward) = 2ms

Total update time = 9ms maximum

Digital inputs 1, 2 & 3 (6ms) + analogue input (2ms) + mandatory (5ms) = 13ms

If the update time for the digital input destination parameters is 2ms, then the total update time for the digital inputs is 15ms maximum.

If the update time for the analogue input destination parameter is 5ms, then the total update time for the analogue input is 18ms maximum.

** When the analogue input is routed to the precision reference parameters, Pr **1.18** and Pr **1.19**, the worst-case option to drive update time is $4 \times 0.5 = 2\text{ms}$ for Unidrive SP and $4 \times 2 = 8\text{ms}$ for Commander SK. The update time of the precision reference parameters is 5ms, therefore the total update time is 18ms maximum.



0472-0004-03