

# OPTIDRIVE E2

## Ease of Use

AC Variable Speed Drive  
0.37kW – 11kW (0.5 – 15HP)  
110 – 480V

General purpose economy drive with modbus communication

Rich in features the Optidrive E2 is the most commercially competitive Optidrive in the Optidrive family. Innovative and compact the Optidrive E2 range combines good looks with robustness, reliability and easy to use performance.

The product is dedicated to low power applications where total costs are ultra-competitive, including:

- Competitive purchase price
- Low installation costs
- Low commissioning costs
- Low technical support costs

Optidrive E2 has only 14 standard parameters to adjust in its basic form, thus Optidrive's legendary ease of use could not be easier or quicker to get started with. Optidrive E2 can be supplied with or without an internal rfi filter.

### Key Benefits

- Small mechanical envelope
- Rugged industrial 50°C ambient rating for hot and tough applications
- Simple mechanical & electrical installation
- Simple operation, powerful features easy to use
- Fast setup, factory default settings ok for most applications, only 14 basic parameters
- Motor current and rpm indication
- Debugging using troubleshooting & P-00
- 150% overload for 60 secs (175% for 2 secs)
- Keypad control
- Integral RFI filter option
- Integral brake chopper (S2 and S3 only)
- Modbus RTU serial communications



### Industry Sectors

- Food Processing
- Bottling
- Pumping
- Chemical
- Waste Water
- HVAC
- Conveyor



## OPTISTICK Product code: OPT-STICK

For fast and accurate repeat drive programming

Simply insert Optistick into the RJ45 slot on the face of the Optidrive E2:

- Upload/download buttons allow for fast copying of parameters between drives
- Infra red communications capability provides remote control convenience
- Can be programmed with PDA or Smartphone

Specification		OPTIDRIVE E2	
Output Ratings	Overload capacity	150% for 60 secs; 175% for 2 secs	
	Frequency	0...500Hz	
Input Ratings	Frequency	48–62Hz	
	Voltage	110–115V ± 10% 1 Phase (0.5–1.5 HP) 200–240V ± 10% 1 Phase (0.37–4kW / 0.5–5 HP) 200–240V ± 10% 3 Phase (0.37–3.7kW / 0.5–5 HP) 380–480V ± 10% 3 Phase (0.75–11kW / 1–15 HP)	
Ambient Conditions	Temperature	Operating: -10 to 50°C max; Storage: -40 to 60°C	
	Altitude	0–2000 m (derate 1% per 100m above 1000m)	
	Ingress protection	IP20; Optional IP55/NEMA 12 & IP66/NEMA 4X	
Programming	Keypad	Yes	
	PC	Yes	
	PDA	Yes	
	Smartphone	Yes	
Control Specification	Control method	Voltage Vector	
	PWM Frequency	4...32kHz (effective)	
	V/Hz ratio	Linear	
	Boost	Yes	
	Stop mode	Coast/Ramp/DC Brake	
	Internal brake transistor	Yes (sizes 2 and 3); External resistor required	
	Capacity	100% Drive Rated Power continuously	
	Skip frequency	One point, adjustable frequency band	
	Frequency setpoint control	0...10V DC	
		20...4mA	
		4...20mA	
		0...20mA	
		Digital–Keypad Modbus RTU	
	Preset speeds	4	
	PI control	Yes	
	Spin start	Yes	
	Acceleration	0...600 secs	
Deceleration	(2 ramps) 0...600 secs		
PC setup software	Optistore V3		
Programmable I/O	Input 1	Programmable Digital Input	
	Input 2	Programmable Digital Input	
	Input 3	User-selectable Analogue / Digital Input	
	Input 4	User-selectable Analogue / Digital Input	
	Output 1	Programmable Analogue / Digital Output	
	Relay 1	Relay Output (30V DC 5A, 250V AC 6A)	
Keypad Display	Operating display	Output Frequency, Current, RPM, Power and User Scalable values	
	Remote mount	Optional Optiport E2 remote mounting keypad	
Protective Functions	Inverter trip	Over voltage, over current, under voltage, external trip, motor overload, over temperature, short circuited, earth fault	
	Memory	Last 4 trips stored	
Bus Communication	Modbus RTU	Standard	
	Profibus DP	via Gateway	
	DeviceNet	via Gateway	
	RS485 (Optibus)	Standard	
Standards Compliance	EN 61800-3:2004	Adjustable speed electrical power drive systems. EMC requirements.	



## OPTIDRIVE E2 Electrical Data in kW with internal rfi filter

200–240V 1 Phase	Motor Power (kW)	Output Current (A)	Frame Size
ODE-2-12037-1KB12	0.37	2.3	1
ODE-2-12075-1KB12	0.75	4.3	1
ODE-2-12150-1KB12	1.5	7	1
ODE-2-22150-1KB42	1.5	7	2
ODE-2-22220-1KB42	2.2	10.5	2
ODE-2-32040-1KB42	4	16	3

200–240V 3 Phase	Motor Power (kW)	Output Current (A)	Frame Size
ODE-2-12037-3K012#	0.37	2.3	1
ODE-2-12075-3K012#	0.75	4.3	1
ODE-2-12150-3K012#	1.5	7	1
ODE-2-22150-3KB42	1.5	7	2
ODE-2-22220-3KB42	2.2	10.5	2
ODE-2-32040-3KB42	4	18	3

**Note:** Suitable for use on single phase supply with 50% derating  
# Size 1, 3 Phase Input drives are not available with internal rfi filter

380–480V 3 Phase	Motor Power (kW)	Output Current (A)	Frame Size
ODE-2-14075-3KA12	0.75	2.2	1
ODE-2-14150-3KA12	1.5	4.1	1
ODE-2-24150-3KA42	1.5	4.1	2
ODE-2-24220-3KA42	2.2	5.8	2
ODE-2-24400-3KA42	4	9.5	2
ODE-2-34055-3KA42	5.5	14	3
ODE-2-34075-3KA42	7.5	18	3
ODE-2-34110-3KA42	11	24	3

## OPTIDRIVE E2 Electrical Data in HP without internal rfi filter

110–115V 1 Phase	Motor Power (HP)	Output Current (A)	Frame Size
ODE-2-11005-1H012	0.5	2.3	1
ODE-2-11010-1H012	1	4.3	1
ODE-2-21015-1H042	1.5	5.8	2

**Note:** 230V, 3 phase output (Voltage Doubler)

200–240V 1 Phase	Motor Power (HP)	Output Current (A)	Frame Size
ODE-2-12005-1H012	0.5	2.3	1
ODE-2-12010-1H012	1	4.3	1
ODE-2-12020-1H012	2	7	1
ODE-2-22020-1H042	2	7	2
ODE-2-22030-1H042	3	10.5	2
ODE-2-32050-1H042	5	16	3

200–240V 3 Phase	Motor Power (HP)	Output Current (A)	Frame Size
ODE-2-12005-3H012	0.5	2.3	1
ODE-2-12010-3H012	1	4.3	1
ODE-2-12020-3H012	2	7	1
ODE-2-22020-3H042	2	7	2
ODE-2-22030-3H042	3	10.5	2
ODE-2-32050-3H042	5	18	3

**Note:** Suitable for use on single phase supply with 50% derating

380–480V 3 Phase	Motor Power (HP)	Output Current (A)	Frame Size
ODE-2-14010-3H012	1	2.2	1
ODE-2-14020-3H012	2	4.1	1
ODE-2-24020-3H042	2	4.1	2
ODE-2-24030-3H042	3	5.8	2
ODE-2-24050-3H042	5	9.5	2
ODE-2-34075-3H042	7.5	14	3
ODE-2-34100-3H042	10	18	3
ODE-2-34150-3H042	15	24	3

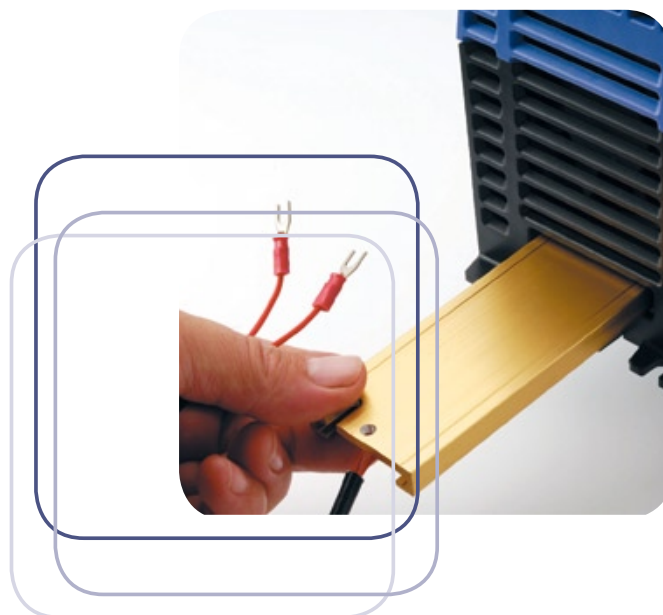



### OPTIDRIVE E2 Dimensions

Size	Height (mm)	Width (mm)	Depth (mm)	Weight (kg)	Fixings
1	173	82	123	1.1	4 × M4
2	221	104	150	2.6	4 × M4
3	261	131	175	4.0	4 × M4



### OPTIDRIVE E2 Part Number Designation

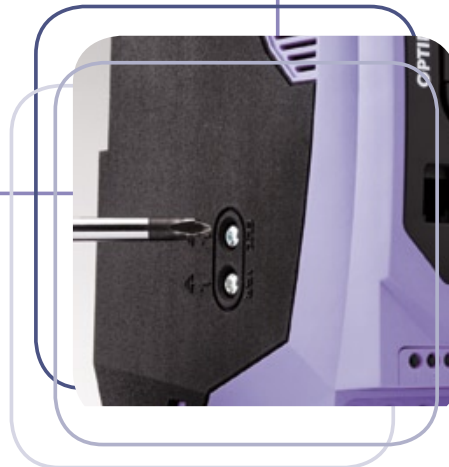
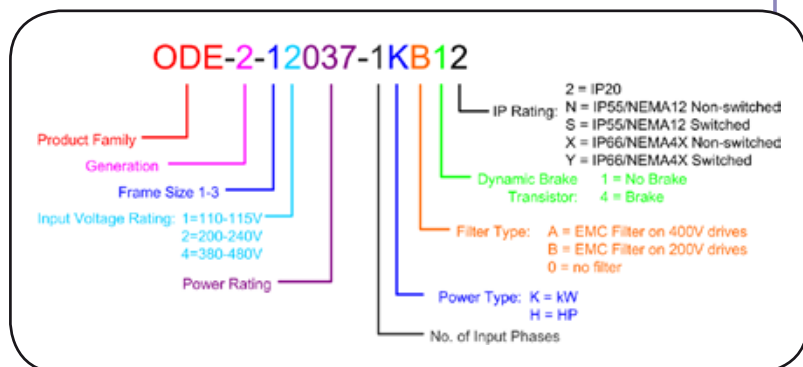

EMC and Varistor disconnect

### Options

Product	Description
OptiFilter	RFI Line Filter
Optibrake	Dynamic Braking Resistor
Input Chokes	Mains Supply Input Chokes
Output Filters	Motor Output Filter, recommended for long motor cable runs
2ROUT	2 Relay Output Option
HVACO	2 Relay Output for HVAC operation
LOGIP	High Voltage Logic Input Option
Optiport E2	Optiport Plus remote mounting keypad
Network Cables	RJ45 Cables and Splitters
PC Connection Kit	Isolated RS485 USB Adaptor
Optiwand PDA / SP	Commissioning and backup software for Pocket PC / PDA
Optistore V3	Commissioning and Storage Software for PC
Fieldbus Gateway	DeviceNet, Profibus and Ethernet gateways