

Electromechanical products Poulibloc

General information



Poulibloc geared motors with parallel gears are used to adapt the speed of the electric motor to that of the driven machine. Their size is therefore determined by the motor power (P) expressed in kilowatts (kW) and the output rotation speed of the gear box (n_S) in revolutions per minute (min^{-1}).

The main characteristic of the speed reducers is the rated output torque (M_{nS}) expressed in Newton-metre (N.m) :

$$M_{nS} = \frac{P \times 9550}{n_S} \times \text{efficiency}'$$

1. η gear x η pulley-belt

- A range of eight sizes for Pb 2000 series: 20, 21, 22, 23, 24, 25, 26, 27.

Rated output torque: from 10 N.m to 10000 N.m.

Power rating: from 0.25 to 55 kW.

Reduction ratios: from 5.5 to 25.

From one to two reduction stages.

High efficiency: 96 % to 98 %.

Reversible.

- A range of three sizes for Pb 3000 series: 30, 31, 32 lubricated with grease. Nominal output torque up to 820 N.m.

- A range of three sizes for Pbh 3000 series: 31, 32, 33, lubricated with oil. Rated output torque up to 1100 N.m.

Power rating: from 0.37 to 11 kW.

Reduction ratios: 5 to 8.

Construction

Description of Poulibloc (Pb) gearboxes

Component	Materials	Remarks
Housing	Cast iron	- use of FGL cast iron (flake graphite: tensile strength 150 MPa) single component perlite to ensure the complete sealing of the unit - monobloc with reinforced internal ribbing to absorb vibrations and noise and to increase rigidity - they are compact and meet industrial application-related requirements
Gears	Steel and C 45	- cut by gear hob, they are heat treated, then undergo a final machining. The quality and the precision of the gear cutting allow maximum torque with minimum noise level
Shaft	Steel	- grinding of the sealing surfaces - Pb 2000: taper bush and tightening key ; Pb 3000: keyed hollow shaft - diameter tolerances in accordance with IEC 72-1 (DIN 748)
Seals	Acrylonitrile	- anti-dust lipseals according to DIN 3760 AS form
Torque bracket	Steel	- can be orientated in three positions when mounting the belt tension arm delivered with Poulibloc 2000
Lubrication	Oil	- in accordance with ISO 6743/6 - For Pb 2000: delivered without oil, fill in accordance with the operating position. It is fitted with drain, level and vent plugs - For Pbh 31 to Pbh 33: delivered without oil, fill in accordance with the operating position. It is fitted with drain, level and vent plugs
	Grease	- For Pb 30 to Pb 32: delivered lubricated for 10 000 operating hours
Mounting		AP: gearbox with input shaft
Finish	Paint	Shade: RAL 6000 (green), system I (1 couche polyurethane vinyl layer of 25/30 μm)

Electromechanical products Poulibloc

Mounting positions

Standard position: gearbox seen from side F, input shaft to the rear.

Fixing

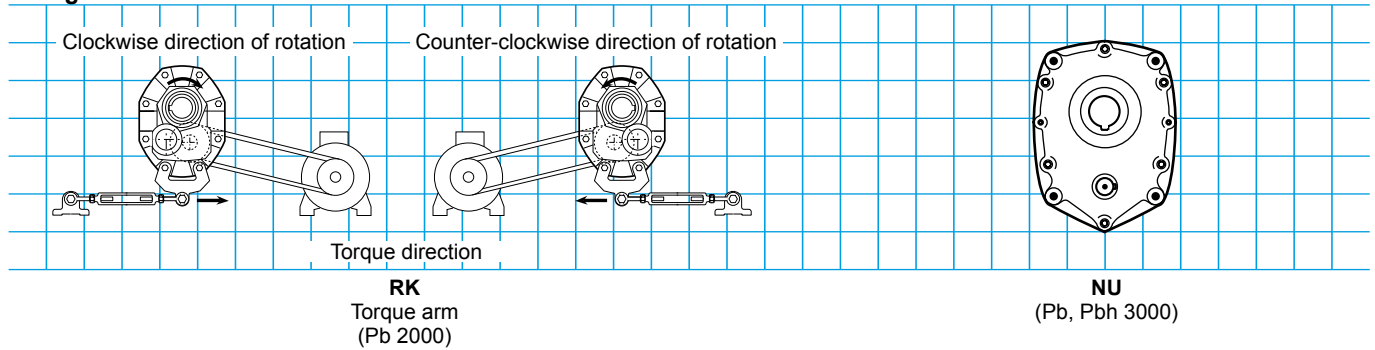

Standard position: delivered without oil, it is multiposition: **M**

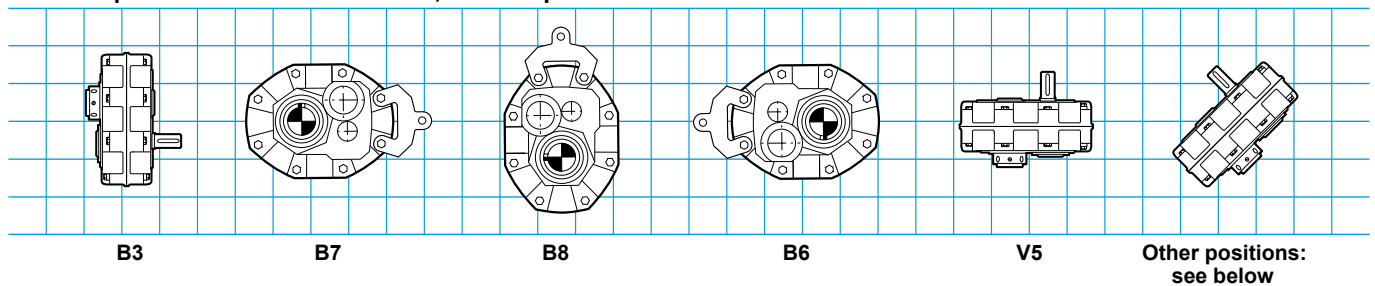

Fill in accordance with the operating position.

Other positions

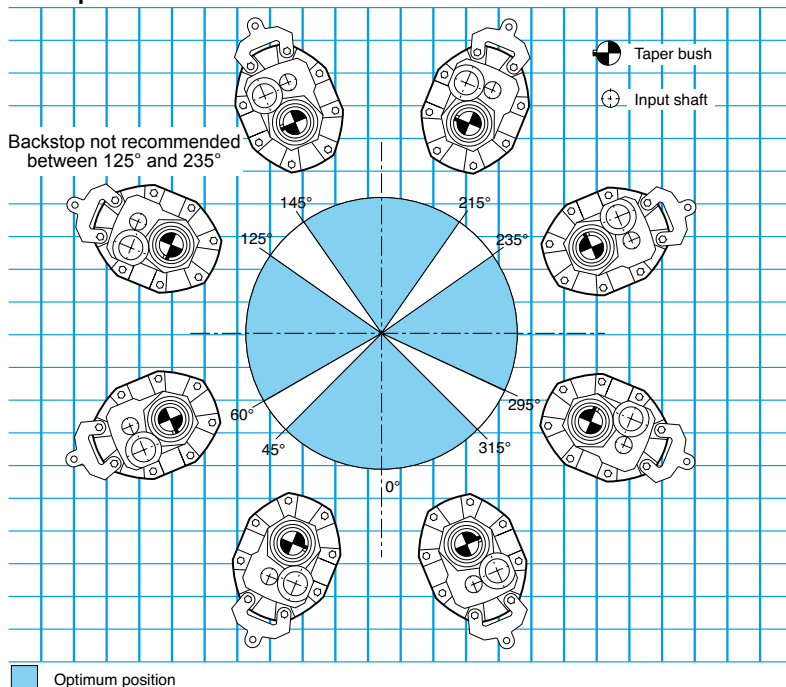

Limits to mounting arrangements

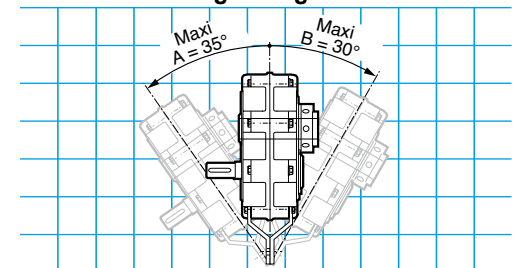

Output shaft

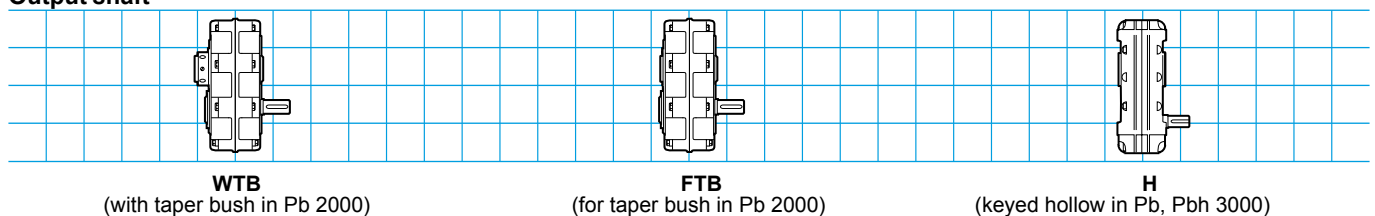

Electromechanical products Poulibloc 2000

Adaptation possibilities

Leroy-Somer offers several drives for its gearboxes which meet a diverse range of needs. They are described below and offered in this catalogue in the section relating to gearboxes. For other drives, consult Leroy-Somer technical specialists who will be pleased to assist you.

A backstop can be fitted on Poulibloc gearboxes series Pb 2000:

The backstop is delivered separately in kit form for types Pb 20--, 21--, 22--, 23--, 24--.

It can be delivered ready fitted on types Pb i: 5 and Pb 25--, 26--, 27-- and in Atex environments.

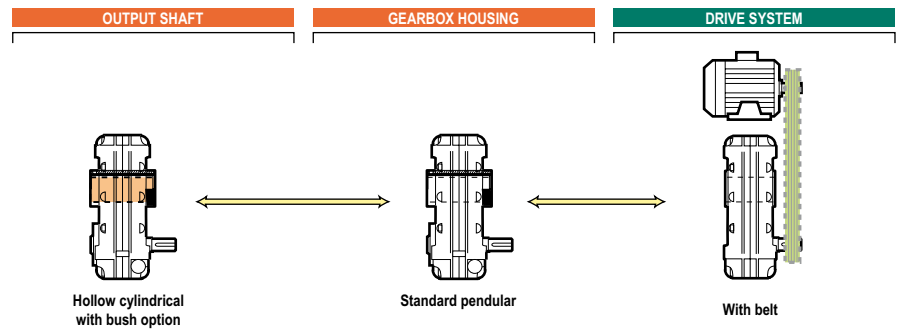

Designation

Pb	2020	20.6	RK	WTB	40 H7	M	AP	AD
Type	Size and manufacturer code	Exact reduction	Mounting form	Type of output shaft	∅ taper bush mounted	Operating position	Type of input Input shaft	Option: Backstop Clockwise direction of rotation

Example:

Poulibloc 2020 1.5 kW, 35.5 min⁻¹, class II, taper bush

Designation:

Pb 2020 i: 20.6 RK-WTB 40 H7 M APAD

Each electromechanical product is classified first in order of power and then in order of speed.

Electromechanical products Poulibloc 3000

Adaptation possibilities

Leroy-Somer offers several drives for its gearboxes which meet a very wide-range of needs. They are offered in this catalogue, in the section relating to fixed speed motors, in the chapter A. For other drives, consult Leroy-Somer technical specialists who will be pleased to assist you.

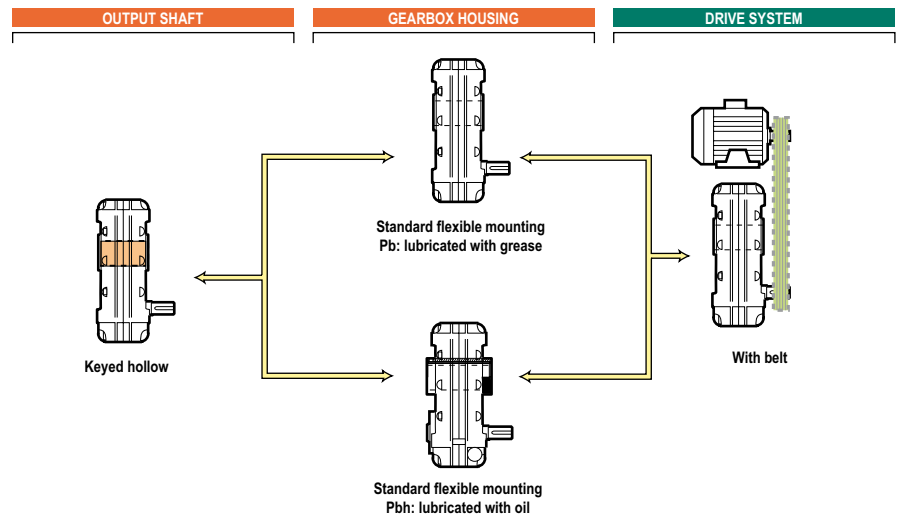

Designation

Pb	3208	7.85	NU	-	H	40 G7	M	AP
Serie	Size and manufacturer code	Exact reduction	Mounting form	Mounting position	Type of output shaft	Ø output shaft	Operating position	Type of input Input shaft

Example:

Poulibloc 3208 3 kW, 90 min⁻¹, class II, hollow shaft Ø 35

Designation:

Pb 3208 i: 7.85 NU - H 40 G7 M AP

Each electromechanical product is classified first in order of power and then in order of speed.

Electromechanical products Poulibloc

Selection

The selection of a gearbox or of a geared motor should take account of the application. Some of these applications are listed in the indicative "AGMA" load classification, page D0.10.

The opposite table summarises the relationship between the "AGMA" class and the gearbox duty factor K_p .

"AGMA" class	Gearbox duty factor K_p
I	1
II	1.4
III	2

1st case. – Your application is listed

Follow the indicative "AGMA" load classification table, page D0.10 of this catalogue.

Indicative "AGMA" load classification

Applications

	Operation in hours / day		
	3h/day	10h/day	24h/day
CONVEYORS (loaded or fed uniformly)			
belt	I	I	II
chain	I	I	II

Application example: Belt CONVEYOR

Operating time: 10 hours / day

"AGMA" class: I

Gearbox duty factor $K_p = 1$

2nd case. – Your application is not listed

The "AGMA" selection class is defined by the daily operating time and by the application operating type, according to the table below. ▼

Type of application	Daily operating time	"AGMA" class
Shock-free, few starts	10 hours/day	I
Damped shocks	10 hours/day	II
Shock-free, few starts	24 hours/day	III
Violent shocks, many starts	10 hours/day	III
Damped shocks	24 hours/day	III

Electromechanical products Poulibloc

Selection

Mechanical forms:
Poulibloc 2000

Maximum quantity by order

i	Pb 20	Pb 21	Pb 22	Pb 23	Pb 24	Pb 25	Pb 26	Pb 27
5	2	5	2	5	2	5	2	5
12	2	5	2	5	2	5	2	5
15								
20	2	5	2	5	2	5	2	5
25								
RK: torque arm								
bush Ø 20H7								
bush Ø 25H7								
bush Ø 30H7								
bush Ø 35H7								
bush Ø 40H7								
bush Ø 45H7								
bush Ø 50H7								
bush Ø 55H7								
bush Ø 60H7								
bush Ø 65H7								
bush Ø 70H7								
bush Ø 75H7								
bush Ø 80H7								
bush Ø 85H7								
bush Ø 90H7								
bush Ø 95H7								
bush Ø 100H7								
bush Ø 110H7								
bush Ø 120H7								
Backstop AD								
Pages of dimensions								
Pb 20 to 27	D2.14	D2.14	D2.14	D2.14	D2.14	D2.14	D2.14	D2.15
Driven shaft					D2.16			

Mechanical forms:
Poulibloc 3000

Maximum quantity by order

i	Pb 30	Pb 31	Pbh 31	Pb 32	Pbh 32	Pbh 33
NU						
5						
8						
H Ø 25G7						
H Ø 30G7						
H Ø 35G7						
H Ø 40G7						
H Ø 45G7						
H Ø 50G7						
H Ø 55G7						
H Ø 60G7						
<i>1. i = 8 exclusively</i>						
Pages of dimensions						
Pb 30 to 32	D2.17					
Pbh 31 to 33	D2.18					

DG

<

2 WD

<

5 WD

<

10 WD

<

15 WD

<

To agree

DG: Availability ; n WD: Working Days (at the departure of the factory).

Electromechanical products Poulibloc

Selection

Exact reductions

VERSION WITHOUT OIL				GREASE VERSION				VERSION WITHOUT OIL							
Type	Exact reduction	Designation	Reduction	Type	Exact reduction	Designation	Reduction	Type	Exact reduction	Designation	Reduction				
Pb 20--	05	Pb 2005	5.50	Pb 30--	05	Pb 3005	5								
	12	Pb 2012	12.9		Pb 31--	05	Pb 3105					5.08			
	15	Pb 2015	15.5	08		Pb 3108	8								
	20	Pb 2020	20.6			Pb 32--	05					Pb 3205	5.07		
	25	Pb 2025	24.8	08	Pb 3208		7.85								
Pb 21--	05	Pb 2105	5.62									Pbh 31--	-	-	-
	12	Pb 2112	11.5										-	-	-
	15	Pb 2115	14.6									05	Pbh 3105	5.08	
	20	Pb 2120	20.6									08	Pbh 3108	8	
	25	Pb 2125	26.1									Pbh 32--	05	Pbh 3205	5.07
Pb 22--	05	Pb 2205	5.54					08	Pbh 3208	7.85					
	12	Pb 2212	11.6					Pbh 33--	08	Pbh 3308	7.85				
	15	Pb 2215	14.5												
	20	Pb 2220	19.5												
	25	Pb 2225	24.5												
Pb 23--	05	Pb 2305	5.62												
	12	Pb 2312	12.2												
	15	Pb 2315	15.2												
	20	Pb 2320	20.6												
	25	Pb 2325	25.7												
Pb 24--	05	Pb 2405	5.50												
	12	Pb 2412	12.3												
	15	Pb 2415	14.4												
	20	Pb 2420	20.8												
	25	Pb 2425	24.4												
Pb 25--	05	Pb 2505	5.69												
	12	Pb 2512	12.4												
	15	Pb 2515	14.8												
	20	Pb 2520	20.5												
	25	Pb 2525	24.3												
Pb 26--	05	Pb 2605	5.50												
	12	Pb 2612	12.5												
	15	Pb 2615	14.7												
	20	Pb 2620	21.1												
	25	Pb 2625	24.8												
Pb 27--	12	Pb 2712	12.3												
	20	Pb 2120	20.9												

D

Electromechanical products Poulibloc 2000

Selection

Class
II
($k_p = 1.4$)

Poulibloc (Pb) gearboxes
RK form, with TB taper bush
Pb 2005 to Pb 2720

Input shaft mounting **AP**

Pb 2000

min ⁻¹	kW																				
	0.37	0.55	0.75	0.9	1.1	1.5	1.8	2.2	3	4	5.5	7.5	9	11	15	18.5	22	30	37	45	55'
	4 poles																				
	71	80	90	100	112	125	140	160	180	200	225	250									
													2 stages, reductions: 12, 15, 20 and 25 ²								
25										2425		2525									
28		2025			2125		2225		2325		2425										
31.5				2025			2225		2320		2420		2520			2625					
35.5			2020					2120	2220							2620					
40																					
45				2015						2315		2415	2515	2520		2615			2720		
50							2115		2215			2315									
56								2212					2412								
63														2512							
71			2012										2315					2612			
80														2412							
90										2212		2312									2712
100									2112												
112														2315	2412						
125											2212										
140																					
													1 stage, reduction: 5 ²								
112																					
125																					
140																					
160																					
180									2005					2205	2405	2505					
200													2105	2305							2605
225																					
250																					
280																					
315																					

1. LS B35 obligatory

2. i Poulibloc selected depending on the pulley Ø ratio of 1/1, 1/2 or 1/3

Selection example

Required power:	4 kW
Required speed:	62 min ⁻¹
Duty factor necessary for the application:	Kp = 1.4
Diameter of driven shaft:	45
Mounting:	torque arm

Designation: Pb 2112 i: 11.5 RK W TB Ø 45H7 M AP (motor LS 112M 4 kW - pulley ratio 1/2) or
Pb 2120 i: 20.6 RK W TB Ø 45H7 M AP (motor LS 112M 4kW - pulley ratio 1/1.2)

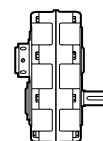

DG	<	2 WD	<	5 WD	<	10 WD	<	15 WD	<	To agree
----	---	------	---	------	---	-------	---	-------	---	----------

DG: Availability ; n WD: Working Days (at the departure of the factory).

Electromechanical products

Poulibloc 2000

Selection

Class
III
($k_p = 2$)

Poulibloc (Pb) gearboxes
RK form, with TB taper bush
Pb 2005 to Pb 2720

Input shaft mounting **AP**

Pb 2000

min ⁻¹	kW																				
	0.37	0.55	0.75	0.9	1.1	1.5	1.8	2.2	3	4	5.5	7.5	9	11	15	18.5	22	30	37	45	55'
	4 poles																				
	71	80	90	100	112	132	160	180	200	225	250	2 stages, reductions: 12, 15, 20 and 25 ²									
25			2025						2325		2425										
28					2125		2225				2525				2625						
31.5					2120		2320			2420											
35.5			2020				2220							2620							
40							2120				2420		2520				2720				
45			2015							2315		2415	2515			2615					
50							2115	2215					2412								
56																					
63																					
71							2015		2212				2412								
80				2012												2612					2712
90															2512						
100								2112				2312									
112										2212				2412							
125																					
140																					
	1 train, réduction : 5 ²																				
112																					
125																					
140																					
160																					
180									2005				2205		2305		2505				
200												2105			2405		2605				
225																					
250																					
280																					
315																					

1. LSES B35 obligatory

2. i Poulibloc selected depending on the pulley Ø ratio 1/1, 1/2 or 1/3

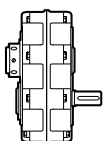

Selection example

Required power: 4 kW
 Required speed: 55 min⁻¹
 Duty factor necessary for the application: $K_p = 2$
 Diameter of driven shaft: 45
 Mounting: torque arm
Designation: Pb 2315 i: 15.2 RK W TB Ø 45H7 M AP (motor LSES 112M 4 kW - pulley ratio 1/1.6) or Pb 2320 i: 20.6 RK W TB Ø 45H7 M AP (motor LSES 112M 4kW - pulley ratio 1/1.2)

DG < 2 WD < 5 WD < 10 WD < 15 WD < To agree

DG: Availability ; n WD: Working Days (at the departure of the factory).

Electromechanical products Poulibloc 3000

Selection

Class
I
(kp = 1)

Poulibloc (Pb) gearboxes
NU form
Pb 3005 to Pb 3308

Input shaft mounting **AP**

Pb 30, 31, 32 - Pbh 31, 32, 33

min ⁻¹	kW																	
	0.37	0.55	0.75	0.9	1.1	1.5	1.8	2.2	3	4	5.5	7.5	9	11	15	18.5	22	30
	4 poles																	
	71	80	90			100			112	132			160	180		200		
1 stage, reductions: 5 and 8'																		
80																		
90																		
100					3108					3208								
112																		
125																		
140																		
160																		
180																		
200					3005					3105		3205			3308			
225																		
250																		
280																		
315																		
355																		

1. i Poulibloc selected depending on the pulley Ø ratio

Selection example

Required power: 3 kW
 Required speed: 200 min⁻¹
 Duty factor necessary for the application: Kp = 1
 Diameter of driven shaft: 35
 Mounting: hollow cylindrical shaft
Designation: Pb 3005 i: 5 NU H Ø 35G7 M AP (motor LSES 100L 3 kW)

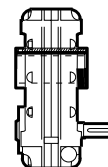

DG < 2 WD < 5 WD < 10 WD < 15 WD < To agree

DG: Availability ; n WD: Working Days (at the departure of the factory).

Electromechanical products

Poulibloc 3000

Selection

Class
II
($k_p = 1.4$)

Poulibloc (Pb) gearboxes
NU form
Pb 3005 to Pb 3308

Input shaft mounting **AP**

Pb 30, 31, 32 - Pbh 31, 32, 33

min ⁻¹	kW																	
	0.37	0.55	0.75	0.9	1.1	1.5	1.8	2.2	3	4	5.5	7.5	9	11	15	18.5	22	30
	4 poles																	
	71	80	90			100			112	132			160	180		200		
	1 stage, reductions: 5 and 8'																	
80																		
90																		
100				3108					3208									
112																		
125																		
140																		
160																		
180																		
200				3005														
225																		
250									3105		3205		3308					
280																		
315																		
355																		

1. i: Poulibloc selected depending on the pulley Ø ratio

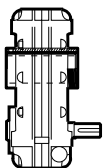

Selection example

Required power: 3 kW

Required speed: 200 min⁻¹

Duty factor necessary for the application: $K_p = 1,4$

Diameter of driven shaft: 35

Mounting: hollow cylindrical shaft

Designation: Pb 3105 i: 5.08 NU H Ø 35G7 M AP (motor LSES 100L 3 kW) or

Pb 3108 i: 8 NU H Ø 35G7 M AP (motor LSES 100L 3 kW)

DG < 2 WD < 5 WD < 10 WD < 15 WD < To agree

DG: Availability ; n WD: Working Days (at the departure of the factory).

Electromechanical products Poulibloc 3000

Selection

Class
III
($k_p = 2$)

Poulibloc (Pb) gearboxes
NU form
Pb 3005 to Pb 3308

Input shaft mounting **AP**

Pb 30, 31, 32 - Pbh 31, 32, 33

min ⁻¹	kW																	
	0.37	0.55	0.75	0.9	1.1	1.5	1.8	2.2	3	4	5.5	7.5	9	11	15	18.5	22	30
	4 poles																	
	71	80	90			100			112	132			160	180	200			
1 stage, reductions: 5 and 8'																		
80																		
90				3108				3208										
100																		
112																		
125																		
140																		
160																		
180																		
200																		
225					3005				3105		3205				3308			
250																		
280																		
315																		
355																		

1. i Poulibloc selected depending on the pulley Ø ratio

Selection example

Required power: 4 kW
 Required speed: 200 min⁻¹
 Duty factor necessary for the application: $K_p = 2$
 Diameter of driven shaft: 40
 Mounting: hollow cylindrical shaft
Designation: Pb 3205 i: 5.07 NU H Ø 40G7 M AP (motor LSES 112M 4 kW)

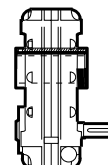

DG < 2 WD < 5 WD < 10 WD < 15 WD < To agree

DG: Availability ; n WD: Working Days (at the departure of the factory).

Electromechanical products Poulibloc 2000

Dimensions

Dimensions of Poulibloc (Pb) gearboxes, Pb 2005 to Pb 2625

Dimensions in millimetres

- With mounting bracket' and TB taper bush

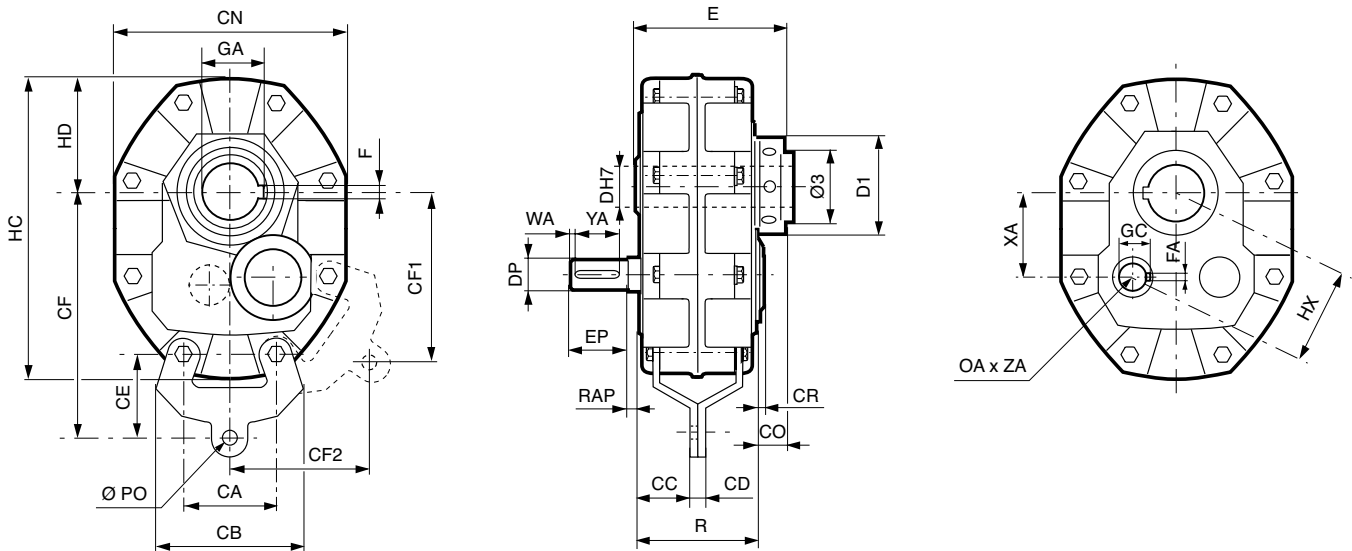

1. Mounting bracket mounted ; dimensions of torque arm on page D2.16

Type	Gearboxes																	kg
	CA	CB	CC	CD	CE	CF	CF1	CF2	CN	CO	CR	HC	HD	HX	PO	R	XA	
Pb 26--	179	277	122	20	130	440	307	247	410	58	23	522	191	192	17	238	172.2	158
Pb 25--	156	234	109	16	110	377	264	212	357	44	13	452	165	164	17	210	147.7	106
Pb 24--	136	213	75	10	100	332	233	191	316	36	13	395	146	145	16	170	131.8	68
Pb 23--	123	190	67	10	80	290	204	156	284	36	13	361	133	126	16	147	112	52
Pb 22--	108	172	61	10	75	260	177	139	252	36	13	320	118	107	16	131	95.8	32
Pb 21--	90.5	162	55	10	72	227	157	130	214	36	13	269	100	92	16	120	84.3	24
Pb 20	82.5	140	48	10	68	210	140	112	198	36	13	245	90	85	16	109	76.6	19

Type	Output shaft and ring						Input shaft								
	Ø3	DH7	D1	E	F	GA	DP	EP	FA	GC	OA	ZA	RAP	WA	YA
Pb 2612 to 2625	M135x3	- ¹	165	300.5	- ¹	- ¹	55	120	16	59	M16	36	0	5	105
Pb 2605	M135x3	- ¹	165	300.5	- ¹	- ¹	48	120	14	51.5	M16	36	0	5	105
Pb 2512 to 2525	M108x3	- ¹	135	259	- ¹	- ¹	50	110	14	53.5	M16	36	0	5	100
Pb 2505	M108x3	- ¹	135	259	- ¹	- ¹	38	80	10	41	M12	26	0	5	100
Pb 24--	M97x3	- ¹	121	207	- ¹	- ¹	50	110	14	53.5	M16	36	0	5	100
Pb 23--	M80x2	- ¹	106	184	- ¹	- ¹	35	80	10	38	M12	26	0	3	72
Pb 22--	M68x2	- ¹	96	171	- ¹	- ¹	32	80	10	35	M10	22	0	4	72
Pb 21--	M64x2	- ¹	86	158	- ¹	- ¹	28	60	8	31	M10	22	0	6	48
Pb 20	M52x2	- ¹	75	138	- ¹	- ¹	24	60	8	27.5	M8	19	0	6	48

1. DH7, F, GA: see page D2.16

Electromechanical products Poulibloc 2000

Dimensions

Dimensions of driven shaft for Poulibloc (Pb) gearboxes, Pb 2005 to Pb 2720,
with taper bushes and torque arm

Dimensions in millimetres

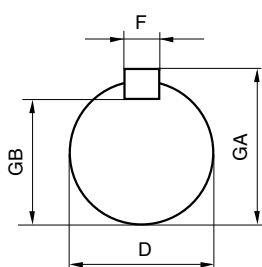

Small-bore client shaft

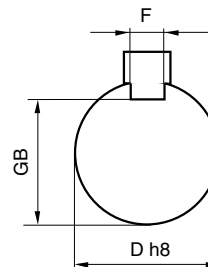

Large-bore client shaft

DH7	Standard bores			Taper bushes							
	F	GB	GA	20	21	22	23	24	25	26	27
20	6	16.5	22.5	•							
25	8	21	28	•	•						
30	8	26	33	•	•	•					
35	10	30	38	••	•	•	•				
40	12	35	43	••	•	•	•				
45	14	39.5	48.5		••	•	•	•			
50	14	44.5	53.5		••	••	•	•			
55	16	49	59			••	••	•			
60	18	53	64				••	•	•		
65	18	58	69					•	•		
70	20	62.5	74.5					••	•	•	
75	20	67.5	79.5					••	•	•	
80	22	71	85						••	•	
85	22	76	90						••	•	
90	25	81	95							•	
95	25	86	100							••	
100	28	90	106							••	•
110	28	100	116								•
120	32	109	127								•
				Minimum length of client shaft							
				80	82	105	116	134	153	194	260

• Client key with small bores, dimensions GA shown.

•• Key supplied, dimensions GA not shown.

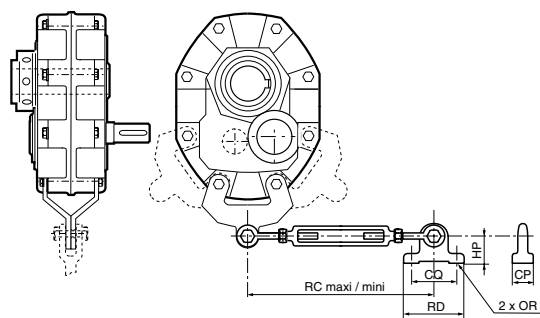

Type	Torque arm						
	CP	CQ	HP	OR	RC max	RC min	RD
Pb 27--	80	210	80	32	840	670	280
Pb 26--	50	105	45	17	540	440	144
Pb 25--	50	105	45	17	540	440	144
Pb 24--	53	95	38	15	450	365	150
Pb 23--	53	95	38	15	450	365	150
Pb 22--	53	95	38	15	450	365	150
Pb 21--	53	95	38	15	450	365	150
Pb 20--	53	95	38	15	450	365	150

The torque arm should be positioned in line with the mounting bracket.

3 positions are possible.

The torque arm should always operate under traction.

Electromechanical products

Poulibloc 3000

Dimensions

Dimensions of Poulibloc (Pb) gearboxes,
Pb 3005 to Pb 3208

Dimensions in millimetres

- With hollow cylindrical shaft

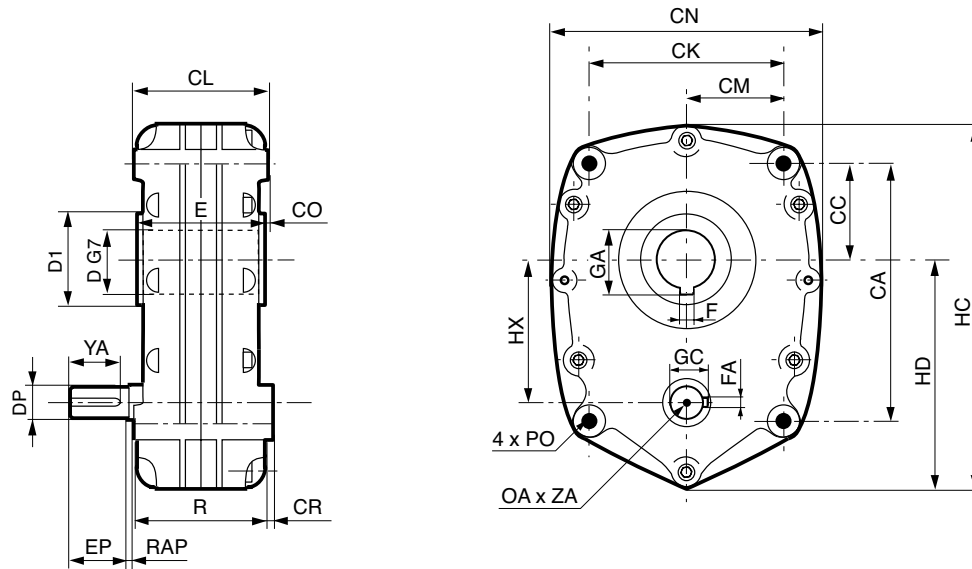

Gearboxes														
Type	CA	CC	CK	CL	CM	CN	CO	CR	HC	HD	HX	PO	R	 kg
Pb 32--	255	110	200	125	100	300	4	13	350	200	134	M14	117	32
Pb 31--	200	85	170	106	85	240	3.5	13	295	172	105	M12	99	20
Pb 30--	160	65	130	80	65	185	3	13	229	136	82	M10	74	12

Input shaft								
Type	DP	EP	FA	GC	YA	OA	ZA	RAP
Pb 3208	28j6	65	8	31	55	M8	19	0
Pb 3205	32j6	65	10	35	55	M8	19	0
Pb 3108	24j6	50	8	27	45	M8	19	0
Pb 3105	28j6	60	8	31	55	M8	19	0
Pb 3005	24j6	50	8	27	45	M8	19	0

Hollow output shaft					
Type	D	D1	E	F	GA
Pb 32--	40	65	117	12	43.3
Pb 32--	45	65	117	14	48.8
Pb 32--	50	65	117	14	53.8
Pb 31--	30	55	99	8	33.3
Pb 31--	35	55	99	10	38.3
Pb 31--	40	55	99	12	43.3
Pb 30--	25	55	74	8	28.3
Pb 30--	30	55	74	8	33.3
Pb 30--	35	55	74	10	38.3

Electromechanical products

Poulibloc 3000

Dimensions

Dimensions of Poulibloc (Pbh) gearboxes,
Pbh 3104 to Pbh 3308

Dimensions in millimetres

- With hollow cylindrical shaft

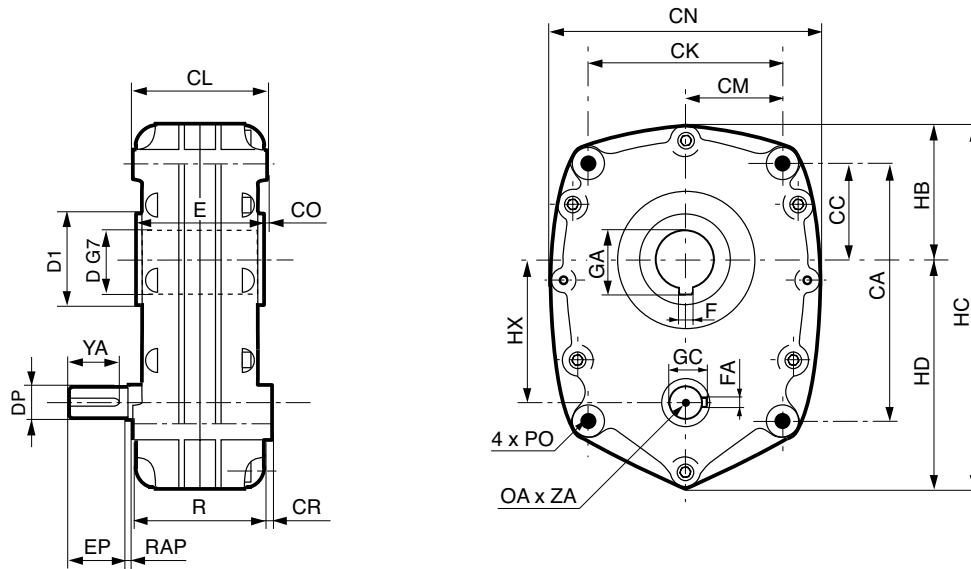

Type	Gearboxes														kg
	CA	CC	CK	CL	CM	CN	CO	CR	HB	HC	HD	HX	PO	R	
Pbh 33--	291	123.4	194.2	138	97.1	312	14.3	13	157	377	220	148.8	M16	209	40
Pbh 32--	255	110	200	125	100	300	9.5	13	150	350	200	134	M14	117	32
Pbh 31--	200	85	170	106	85	240	10	13	123	295	172	105	M12	99	20

Type	Input shaft							
	DP	EP	RAP	FA	GC	YA	OA	ZA
Pbh 3308	30j6	68	0	8	33.3	60	M8	19
Pbh 3208	28j6	65	9	8	31.3	55	M8	19
Pbh 3205	32j6	65	9	10	35.3	55	M8	19
Pbh 3108	24j6	50	2	8	27.3	45	M8	19
Pbh 3105	28j6	60	2	8	31.3	55	M8	19

Type	Hollow output shaft				
	D	D1	E	F	GA
Pbh 3308	50	80	166.5	14	53.8
Pbh 3308	55	80	166.5	16	59.3
Pbh 3308	60	80	166.5	18	64.4
Pbh 32--	40	65	144	12	43.3
Pbh 32--	45	65	144	14	48.8
Pbh 32--	50	65	144	14	53.8
Pbh 31--	30	55	126	8	33.3
Pbh 31--	35	55	126	10	38.3
Pbh 31--	40	55	126	12	43.3